

VEO-XPT24

4K HDBaseT Extender Kit 10.2 GBPS



USER MANUAL

INDEX

| | |
|--|----|
| 1. IMPORTANT REMARK | 3 |
| 2. IMPORTANT SAFETY INSTRUCTIONS | 3 |
| 3. IMPORTANT NOTE | 5 |
| 4. INTRODUCTION | 5 |
| 5. PACKAGE CONTENTS | 6 |
| 6. PANEL DESCRIPTION | 6 |
| 6.1. Transmitter..... | 6 |
| 6.1.1. Front Panel..... | 6 |
| 6.1.2. Rear Panel..... | 7 |
| 6.2. Receiver..... | 7 |
| 6.2.1. Front Panel..... | 7 |
| 6.2.2. Rear Panel..... | 8 |
| 7. CONNECTION AND INSTALLATION | 8 |
| 8. APPLICATION DIAGRAM | 9 |
| 9. TECHNICAL SPECIFICATIONS..... | 10 |

1. IMPORTANT REMARK



WARNING: SHOCK HAZARD - DO NOT OPEN
AVIS: RISQUE DE CHOC ÉLECTRIQUE - NE PAS OUVRIR



The lightning flash with arrowhead symbol, within an equilateral triangle, is intended to alert the user to the presence of uninsulated “dangerous voltage” within the product’s enclosure that may be of sufficient magnitude to constitute a risk of electric shock to persons.



The exclamation point within an equilateral triangle is intended to alert the user to the presence of important operating and maintenance (servicing) instructions in the literature accompanying the appliance.

WARNING (If applicable): The terminals marked with symbol of “” may be of sufficient magnitude to constitute a risk of electric shock. The external wiring connected to the terminals requires installation by an instructed person or the use of ready-made leads or cords.

WARNING: To prevent fire or shock hazard, do not expose this equipment to rain or moisture.

WARNING: An apparatus with Class I construction shall be connected to a mains socket-outlet with a protective earthing connection.

2. IMPORTANT SAFETY INSTRUCTIONS

1. Read these instructions.
2. Keep these instructions.
3. Heed all warnings.
4. Follow all instructions.
5. Do not use this apparatus near water.
6. Clean only with dry cloth.
7. Do not block any ventilation openings. Install in accordance with the manufacturer’s instructions.

8. Do not install near any heat sources such as radiators, heat registers, stoves, or other apparatus (including amplifiers) that produce heat.
9. Do not defeat the safety purpose of the polarized or grounding type plug. A polarized plug has two blades with one wider than the other. A grounding type plug has two blades and a third grounding prong. The wide blade or the third prong are provided for your safety. If the provided plug does not fit into your outlet, consult an electrician for replacement of the obsolete outlet.
10. Protect the power cord from being walked on or pinched particularly at the plugs, convenience receptacles, and at the point where they exit from the apparatus.
11. Only use attachments/accessories specified by the manufacturer.
12. Unplug the apparatus during lightening sorts or when unused for long periods of time.
13. Refer all servicing to qualified personnel. Servicing is required when the apparatus has been damaged in any way, such as power supply cord or plug is damaged, liquid has been spilled or objects have fallen into the apparatus, the apparatus has been exposed to rain or moisture, does not operate normally, or has been dropped.
14. Disconnecting from mains: Switching off the POWER switch all the functions and light indicators of the amplifier will be stopped, but fully disconnecting the device from mains is done unplugging the power cord from the mains input socket. For this reason, it always shall remain readily operable.
15. Equipment is connected to a socket-outlet with earthing connection by means of a power cord.
16. The marking information is located at the bottom of apparatus.
17. The apparatus shall not be exposed to dripping or splashing and that no objects filled with liquids, such as vases, shall be placed on apparatus.

NOTE: This equipment has been tested and found to comply with the limits for a Class A digital device, pursuant to part 15 of the FCC Rules. These limits are designed to provide reasonable protection against harmful interference when the equipment is operated in a commercial environment. This equipment generates, uses, and can radiate radio frequency energy and, if not installed and used in accordance with the instruction manual, may cause harmful interference to radio communications. Operation of this equipment in a residential area is likely to cause harmful interference in which case the user will be required to correct the interference at his own expense.



WARNING: This product must not be discarded, under any circumstance, as unsorted urban waste. Take to the nearest electrical and electronic waste treatment centre.

NEEC AUDIO BARCELONA, S.L. accepts no liability for any damage that may be caused to people, animal or objects due to failure to comply with the warnings above.

3. IMPORTANT NOTE

Thank you for choosing our **VEO-XPT24** 4K HDBaseT extender. It is very important to carefully read this manual and to fully understand its contents before making any connection in order to maximize your use and get the best performance from this equipment.

To ensure optimal operation of this device, we strongly recommend that its maintenance be carried out by our authorised Technical Services.

The **VEO-XPT24** comes with a 3-year warranty.

4. INTRODUCTION

Ecler VEO-XPT24 is a professional HDBaseT transmitter/receiver kit for HDMI extension up to 70 meters over category cable. It supports video signal at resolution up to 4K/UHD with embedded multi-channel audio formats like DTS-HD Master Audio and Dolby TrueHD. The extender kit includes bi-directional IR and RS-232 pass-through. VEO-XPT24 is the ideal solution for commercial point-to-point applications that require extension over greater distances than HDMI can support.

Features:

- Complete extender kit, no configuration needed
- Full HD support: 1080p@60Hz
- 4K/UHD support: up to 4096x2160@30Hz (or 60Hz with YUV 4:2:0)
- 3D support
- Transmission distance up to 70 meters under 1080p and 40 meters under 4K
- Bi-directional IR and RS-232 pass-through
- Use single UTP/STP category cable (CAT-5E/6/7) to substitute HDMI cable to achieve long distance transmission
- POH (RX powered by TX)
- HDCP 2.2/1.4 compliant
- Integrated mounting ears

5. PACKAGE CONTENTS

- 1 x Transmitter Unit
- 1 x Receiver Unit
- 1 x 12V DC International power supply (One PSU for both units)
- 2 x IR Blaster unit (IR emitter and cable, 1 pcs for TX, 1 pcs for RX)
- 2 x IR Receiver unit (IR receiver and cable, 1 pcs for TX, 1pcs or for RX)
- 2 x Phoenix plugs for RS-232 cable termination

6. PANEL DESCRIPTION

6.1. Transmitter

6.1.1. Front Panel

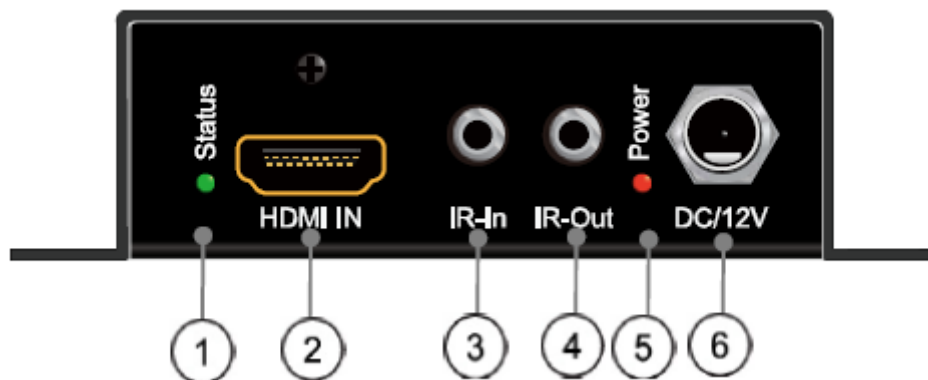

1. HDMI Input link Indicator
2. HDMI Input Port
3. IR Receiver Port
4. IR Transmitter Port
5. Power LED Indicator
6. 12V DC Plug Connector

6.1.2. Rear Panel

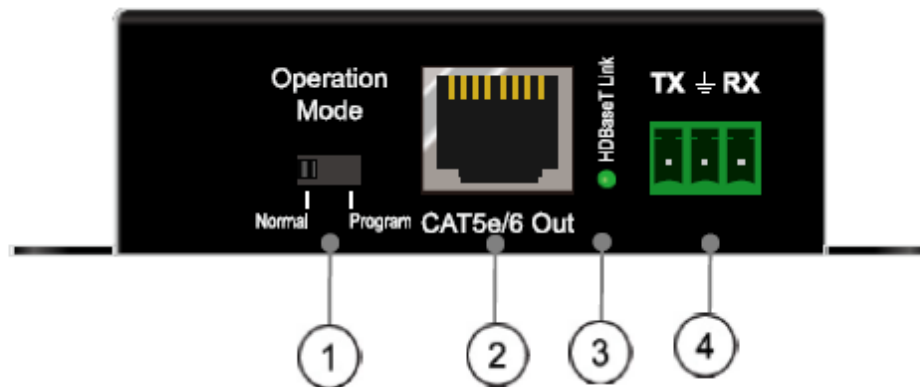

1. RS-232 Function Switch:
 - Normal: RS-232 Pass-Through
 - Program: Firmware Upgrade
2. Cat5e/6/7 Output Port
3. HDBaseT Link Indicator
4. RS-232 Port

6.2. Receiver

6.2.1. Front Panel

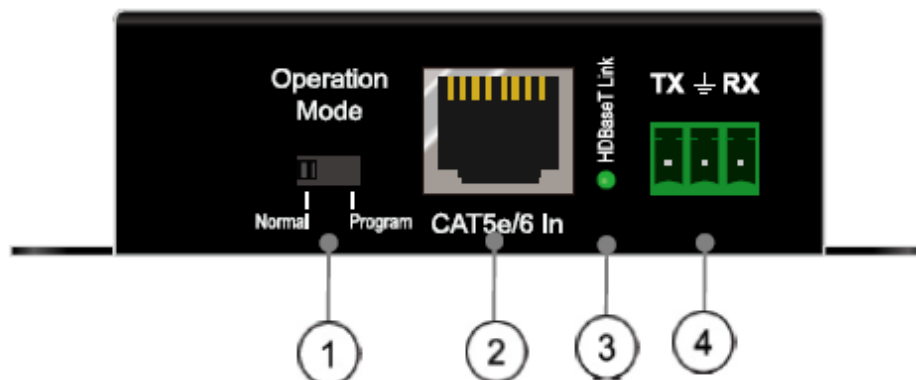

1. RS-232 Function Switch:
 - Normal: RS-232 Pass-Through
 - Program: Firmware Upgrade
2. Cat5e/6/7 Input Port
3. HDBaseT Link Indicator
4. RS-232 Port

6.2.2. Rear Panel

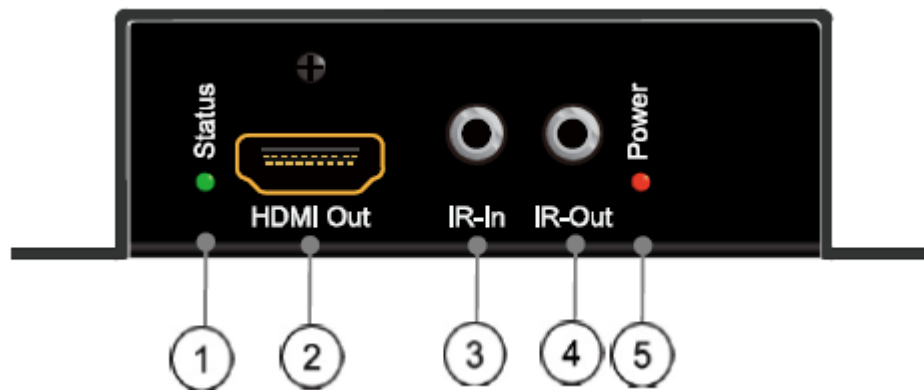

1. HDMI Output Link Indicator
2. HDMI Output port
3. IR Receiver Port
4. IR Transmitter Port
5. Power LED Indicator

7. CONNECTION AND INSTALLATION

1. Connect HDMI signal source (such as PC, Blu-ray player, etc) to HDMI input of VEO-XPT24.
2. Connect Cat5e/6/7 cable from RJ45 output of TX to RJ45 input of RX.
3. Connect HDMI display device (such as 4K or Full HD display) to HDMI output of VEO-XPT24
4. Connect IR Blaster cable into IR-Out port of the Transmitter; Connect the IR Receiver cable into IR-In port of the Receiver.

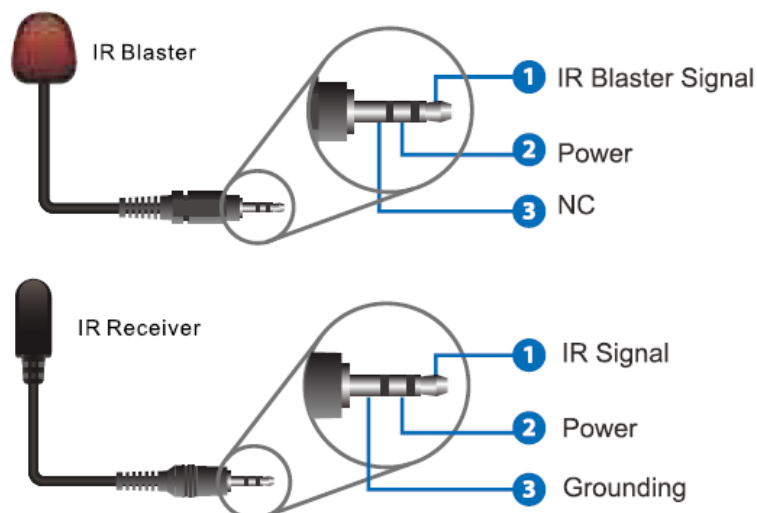

5. Connect IR Receiver cable to IR-In port of the Transmitter; Connect IR Blaster cable to IR-Out port of the Receiver.
6. Phoenix RS-232 Ports can be connected to DTE-DCE devices for pass-through RS-232 transmission.
7. Connect 12V DC power supply to VEO-XPT24 Transmitter.

8. APPLICATION DIAGRAM

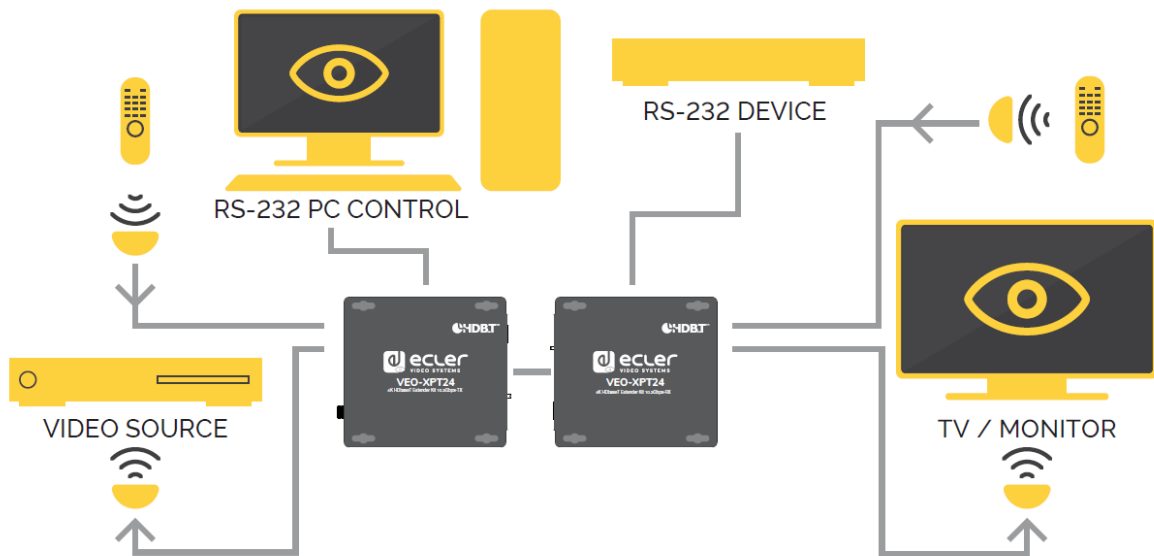

9. TECHNICAL SPECIFICATIONS

Supported Resolutions

4096x2160@24/25/30/50*/60Hz*,
 3840x2160@24/25/30/50*/60Hz*(UHD),
 2048x1080p,1080p@23.98/24/25/29.97/30/50/59
 .94/60Hz,
 1080i@50/59.94/60Hz,720p@50/59.94/60Hz,
 576p, 576i, 480p, 480i

VESA

2560x2048, 2560x1600, 2048x1536, 1920x1200,
 1680x1050, 1600x1200, 1600x900, 1440x900,
 1400x1050, 1366x768, 1360x768, 1280x1024,
 1280x800, 1280x768, 1152x864, 1024x768,
 800x600, 640x480

Colorspace

YCbCr, RGB

Chroma Subsampling

4:4:4, 4:2:2, 4:2:0

Color depth

8-bit, 10-bit, 12-bit, 16-bit only @1080p

Signal Bandwidth

10.2 Gbps

CEC

Pass-through

HDCP

2.2 Compliant

Audio Formats

PCM 2Ch, LPCM 5.1, LPCM 7.1, Dolby Digital, DTS
 5.1, Dolby TrueHD, DTS-HD Master Audio

Sample Rate

32kHz, 44.1kHz, 48kHz, 88.2kHz, 96kHz,
 176.4kHz, 192kHz

Bitrate

up to 24-bit

Distance

Cat5e/6 @ 4K

up to 35 meters / 115 feet

Cat6a/7 @ 4K

up to 40 meters / 130 feet

Cat5e/6 @ 1080p

up to 60 meters / 197 feet

Cat6a/7 @ 1080p

up to 70 meters / 230 feet

| | |
|------------------------------|---|
| HDMI Distance | up to 10 meters (33 ft) with Ecler VEO cables |
| Operating Temperature | -5 to +35°C (41 to +95 °F) |
| Humidity | 5 to 90 % RH (no condensation) |
| Power Consumption | 2.5W (TX), 5W (RX) Maximum |
| Power Supply | AC100~240V 50/60Hz Output: DC 12VDC 2A |
| Dimensions H x W x D | 105mm x 71mm x 25mm (4.13" x 2.79" x 0.98") |
| Weight | 700g / 1.54lbs (Pair) |

*4096x2160@50/60Hz & 3840x2160@50/60Hz supported @ chroma subsampling 4:2:0 8-bit only

All product characteristics are subject to variation due to production tolerances. **NEEC AUDIO BARCELONA S.L.** reserves the right to make changes or improvements in the design or manufacturing that may affect these product specifications.

Motors, 166-168 08038 Barcelona - Spain - (+34) 932238403 | information@ecler.com | www.ecler.com