

MIMO88SG / 1212SG

DIGITAL MATRIXES

Installation Digital Matrix



USER MANUAL

INDEX

1. IMPORTANT REMARK.....	3
2. IMPORTANT SAFETY INSTRUCTIONS.....	3
3. IMPORTANT NOTE.....	5
4. INTRODUCTION.....	5
5. INSTALLATION.....	6
5.1. Location, assembly, ventilation	6
5.2. Connection to an AC outlet and switching on	6
5.3. Signal input connections.....	7
5.4. Audio Output Connections.....	7
5.5. ETHERNET port for programming and control.....	8
5.5.1 Factory Preset Network settings	8
5.6. REMOTE port for digital remote controls.....	8
5.7. GPI Remote Control Ports.....	9
5.8. Remote control RS-232 Port.....	10
5.9. Front panel controls and LED indicators	10
6. CLEANING.....	10
7. FUNCTION LIST.....	11
8. FUNCTION DIAGRAMS.....	12
8.1 MIMO88SG.....	12
8.2. MIMO1212SG	13
9. TECHNICAL CHARACTERISTICS.....	14
9.1. MIMO88SG.....	14
9.2. MIMO1212SG	19
10. BLOCK DIAGRAMS.....	24
10.1. MIMO88SG.....	24
10.1. MIMO1212SG.....	25

1. IMPORTANT REMARK



WARNING: SHOCK HAZARD - DO NOT OPEN
AVIS: RISQUE DE CHOC ÉLECTRIQUE - NE PAS OUVRIR



The lightning flash with arrowhead symbol, within an equilateral triangle, is intended to alert the user to the presence of uninsulated “dangerous voltage” within the product’s enclosure that may be of sufficient magnitude to constitute a risk of electric shock to persons.



The exclamation point within an equilateral triangle is intended to alert the user to the presence of important operating and maintenance (servicing) instructions in the literature accompanying the appliance.

WARNING (If applicable): The terminals marked with symbol of “” may be of sufficient magnitude to constitute a risk of electric shock. The external wiring connected to the terminals requires installation by an instructed person or the use of ready-made leads or cords.

WARNING: To prevent fire or shock hazard, do not expose this equipment to rain or moisture.

WARNING: An apparatus with Class I construction shall be connected to a mains socket-outlet with a protective earthing connection.

2. IMPORTANT SAFETY INSTRUCTIONS

1. Read these instructions.
2. Keep these instructions.
3. Heed all warnings.
4. Follow all instructions.
5. Do not use this apparatus near water.
6. Clean only with dry cloth.
7. Do not block any ventilation openings. Install in accordance with the manufacturer’s instructions.
8. Do not install near any heat sources such as radiators, heat registers, stoves, or other apparatus (including amplifiers) that produce heat.

9. Do not defeat the safety purpose of the polarized or grounding type plug. A polarized plug has two blades with one wider than the other. A grounding type plug has two blades and a third grounding prong. The wide blade or the third prong are provided for your safety. If the provided plug does not fit into your outlet, consult an electrician for replacement of the obsolete outlet.
10. Protect the power cord from being walked on or pinched particularly at the plugs, convenience receptacles, and at the point where they exit from the apparatus.
11. Only use attachments/accessories specified by the manufacturer.
12. Unplug the apparatus during lightning sorts or when unused for long periods of time.
13. Refer all servicing to qualified personnel. Servicing is required when the apparatus has been damaged in any way, such as power supply cord or plug is damaged, liquid has been spilled or objects have fallen into the apparatus, the apparatus has been exposed to rain or moisture, does not operate normally, or has been dropped.
14. Disconnecting from mains: When switching off the POWER switch, all the functions and light indicators of the unit will be stopped, but fully disconnecting the device from mains is done by unplugging the power cable from the mains input socket. For this reason, it always shall remain easily accessible.
15. Equipment is connected to a socket-outlet with earthing connection by means of a power cord.
16. The marking information is located at the bottom of the unit.
17. The apparatus shall not be exposed to dripping or splashing and that no objects filled with liquids, such as vases, shall be placed on apparatus.

NOTE: *This equipment has been tested and found to comply with the limits for a Class A digital device, pursuant to part 15 of the FCC Rules. These limits are designed to provide reasonable protection against harmful interference when the equipment is operated in a commercial environment. This equipment generates, uses, and can radiate radio frequency energy and, if not installed and used in accordance with the instruction manual, may cause harmful interference to radio communications. Operation of this equipment in a residential area is likely to cause harmful interference in which case the user will be required to correct the interference at his own expense.*



WARNING: This product must not be discarded, under any circumstance, as unsorted urban waste. Take to the nearest electrical and electronic waste treatment centre.

NEEC AUDIO BARCELONA, S.L. accepts no liability for any damage that may be caused to people, animal or objects due to failure to comply with the warnings above.

3. IMPORTANT NOTE

Thank you for choosing our Ecler **MIMO88SG / 1212SG Installation Digital Matrix!**

It is **VERY IMPORTANT** to carefully read this manual and to fully understand its contents before any connection in order to maximize your use and get the best performance from this equipment.

To ensure optimal operation of this device, we strongly recommend that its maintenance be carried out by our authorised Technical Services.

Ecler **MIMO88SG / 1212SG** comes with a **3-year warranty**.

4. INTRODUCTION

The MIMO SG is a series of fully programmable digital audio matrixes, with the following features:

- 8 (MIMO88SG) or 12 (MIMO1212SG) balanced MIC/LINE inputs (independent phantom power per input channel).
- 8 (MIMO88SG) or 12 (MIMO1212SG) balanced LINE outputs.
- 8 (MIMO88SG) or 12 (MIMO1212SG) GPI control ports (*General Purpose Input*).
- Programming and remote management via Ethernet using EclerNet Manager (or point to point, with a direct CAT5 cable, or from an Ethernet network).
- Remote control via UCP (User Control Panel) clients on Ethernet: simultaneous clients with customized control panel, such as WPmSCREEN Ecler, Android®, iOS®, Windows®, etc.
- Remote control from third party external devices. (Crestron, AMX, Vity, Medialon, etc. Registered trademarks of their manufacturers). TP-NET protocol, via Ethernet or RS-232 ports.
- Remote control bus for WPTOUCH digital panels and MPAGE16 messaging consoles (*paging*).
- Configuration memory (*presets*) management.
- Scheduled events based on calendar.
- Extensive DSP available:
 - Routing matrix/mixer, from any input to any output with adjustable level for crossover points (independent mixes of different inputs for each output).
 - Mono or stereo channel processing.
 - Level control, mute, vu-meters and phase adjustment for inputs and outputs.
 - Internal signal generator (sine wave, pink noise, white noise, polarity test).
 - Parametric EQ on inputs and outputs.

- Delay on inputs and outputs.
- Gate/compressor on input channels.
- Compressor/limiter on outputs.
- Input channel priority assignment (*ducking*).
- Virtual and physical messaging consoles (*paging*).
- Standard MIMO88SG / MIMO1212SG firmware version (for generic use) and alternative version, for conferencing applications (MIMO88SG / MIMO1212SG CONFERENCE version). Both firmware versions are compatible with the MIMO88SG / MIMO1212SG hardware which can be freely updated with anyone of them.

The MIMO SG programming is done with [EclerNet Manager](#). Please refer to the EclerNet Manager Software manual for more information.

5. INSTALLATION

5.1. Location, assembly, ventilation

MIMO SG series has been especially designed to be installed in a standard 19" rack, taking up 1U.

It is very important not to enclose the MIMO SG or expose it to extreme temperatures as it generates heat. It's also necessary to promote the passage of fresh air through the ventilation holes of the chassis, leaving at least one rack unit off between each device and installed above and below it in the rack frame.

If the setup has several amplifiers in the same rack or in a closed cabinet with doors, it is highly recommended to supply them forced ventilation, installing fans at the upper and lower ends. This upward air flow will help to dissipate the heat generated inside.

5.2. Connection to an AC outlet and switching on

All models in the MIMO SG series operate under voltages between 90 and 264 V at 47 to 63 Hz. This device features an over dimensioned power supply that adapts to the mains voltage in any country of the world with no need to make any adjustments.

On the rear panel, there is a power switch for the unit next to the IEC power connector. On the front panel, a LED lights up when the unit is switched on.

The mains cables must not be near the shielded cables carrying the audio signal, as this could cause humming.

5.3. Signal input connections

The rear panel of a MIMO SG unit offers 8 (MIMO88SG) or 12 (MIMO1212SG) balanced analogue signal inputs, "IN", accepting both line and microphone level signals. Input signal type selection and management are carried out from EclerNet Manager application. Please refer to the EclerNet Manager software manual for more information.

Signal input connectors are 3 position screw terminal block. The wiring is:

- Hot or direct signal > Terminal +
- Cold or inverted signal > Terminal -
- Ground > Terminal ⊥

For unbalanced connection short-circuit pin ⊥ to pin -.

5.4. Audio Output Connections

The rear panel of a MIMO SG offers 8 (MIMO88SG) or 12 (MIMO1212SG) analogue signal outputs "OUT", all balanced and accepting line level signals.

Signal output connectors are 3 position screw terminal block. The wiring is:

- Hot or direct signal > Terminal +
- Cold or inverted signal > Terminal -
- Ground > Terminal ⊥

For UNBALANCED connections, leave the – terminal unconnected.

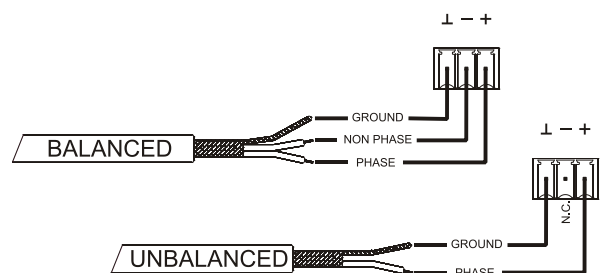

5.5. ETHERNET port for programming and control

An RJ45 type connector allows connecting the equipment to an Ethernet network:

- Management from EclerNet Manager application. Please refer to the EclerNet Manager Software manual for more information.
- Possibility of direct connection (point to point) between a computer and a MIMO SG unit.
- Connection to third party other devices. (Crestron, AMX, Vity, Medialon, etc. Registered trademarks of their manufacturers). Protocol used: Ecler TP-NET. See the TP-NET protocol manual for more information.
- Connection to WPmSCREEN units (remote control of an entire network of EclerNet devices through custom graphic panels).

5.5.1 Factory Preset Network settings

The factory default network settings for EclerNet Manager compatible devices are as follows:

- IP: 192.168.0.100
- Mask: 255.255.255.0
- Gate: 192.168.0.1
- UDP Port: 2210

5.6. REMOTE port for digital remote controls

The REMOTE port allows the connection of digital remote-control devices, such as the WPTOUCH wall panel or the MPAGE16 paging console. The REMOTE port is connected to the digital control bus the remote devices are daisy-chained to, the last one being loaded with a 120 Ω termination resistor between CAN HIGH and CAN LOW.

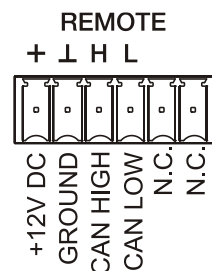

Refer to the remote device documentation (WPTOUCH, MPAGE16, etc) for more information about your connection and controls.

Please refer to the EclerNet Manager Software manual for more information about programming a MIMO SG to manage the remote devices that are connected to the REMOTE port.

5.7. GPI Remote Control Ports

The rear panel of the MIMO SG offers 8 (MIMO88SG) or 12 (MIMO1212SG) GPI inputs for 0-10 VDC continuous control voltage. Each of these inputs can be connected to an external physical device (potentiometer, contact closure, continuously variable voltage 0-10V DC, etc.) and assigned to a MIMO SG function, as for example:

- Input, output channel or matrix crosspoint volume remote control by means of a WpMVOL physical knob or an Ecler WpM Series' WPVOL-IR remote control
- MUTE or SOLO activation/deactivation by means of a switch or contact closure
- Recalling a *preset* with a push button or contact closure

GPI connectors are screw terminal blocks with three-contacts. The wiring is as follows:

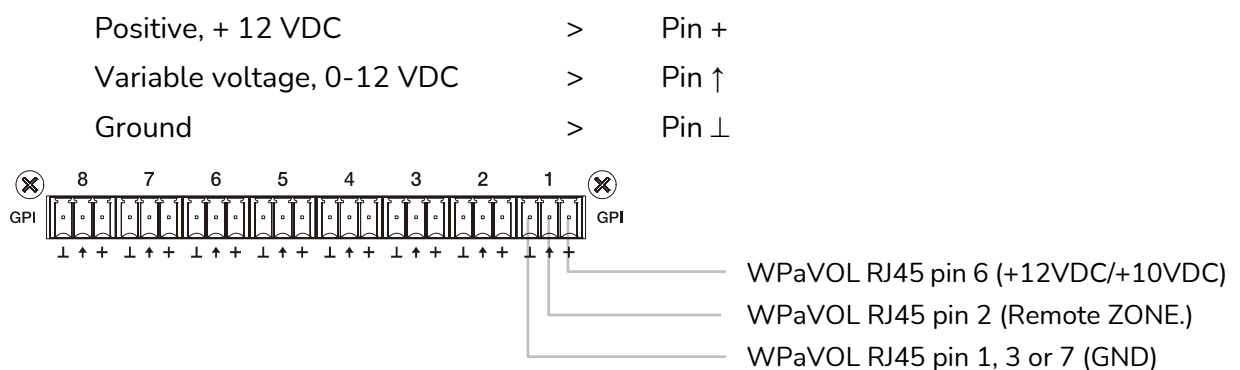

Jumpers position: ALOG / LIN → **LIN position**
 +12 / +10 → **+12 position**

WPaVOL connection to MIMO serial GPI ports

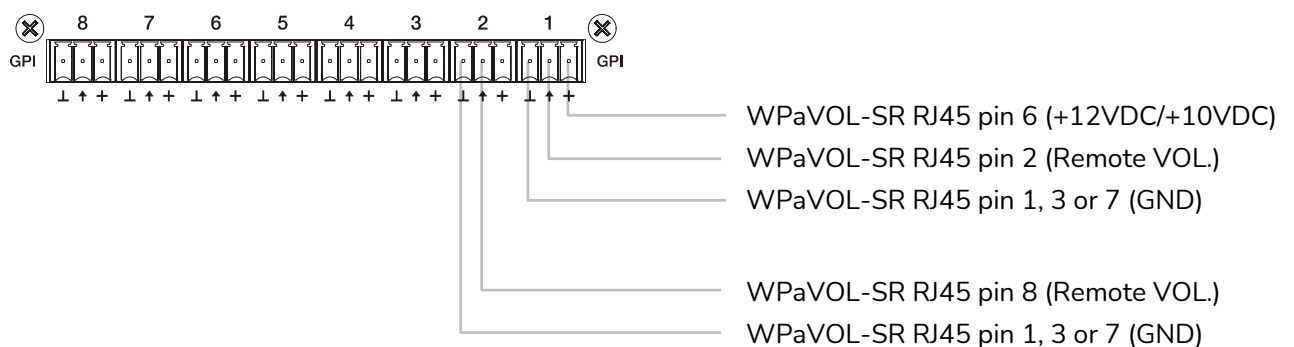

Jumpers position: ALOG / LIN → **LIN position**
 +12 / +10 → **+12 position**

WPaVOL-SR connection to MIMO serial GPI ports

Connecting cables can be up to 500 meters with a minimum section of 0.5 mm².

Consult your ECLER dealer or www.ecler.com about the WP series remote control wall panels and other accessories available for connection to the GPI port.

5.8. Remote control RS-232 Port

The built-in RS-232 port in the rear panel allows an external device to communicate with a MIMO SG unit via serial connection. Said connection uses the TP-NET protocol syntax so to enable the external device to obtain the value of any of the parameters of the MIMO SG unit (by "GET" commands) and/or modify said values ("SET" commands). See the TP-NET protocol manual for more information.

The serial connection should comply with the following specifications:

Baud rate: 57600 (fixed, no auto negotiation)

Data bits: 8

Parity: None

Stop bits: 1

Flow control: None

WIRING RS232 – DB9	
RS232	DB9
Tx	Pin 2 (RxD)
Rx	Pin 3 (TxD)
Gnd	Pin 5 (Signal Gnd)

5.9. Front panel controls and LED indicators

The following elements are available on the MIMO SG series front panel:

- **Input LED indicators:** indicate the presence of audio signal at the unit's input, and its intensity level (green, amber and red indicate in this order the increased intensity level)
- **Output LED indicators:** indicate the presence of audio signal at the unit's output, and its intensity level (green, amber and red indicate in this order the increased intensity level)
- **Status LED indicators (STATUS):**
 - **DATA:** Off: there is no connection to EclerNet Manager even if connected to Ethernet. On: connected to EclerNet Manager or to other third party application via TP-NET protocol. Flashing: data traffic with EclerNet Manager or another application.
 - **POWER:** Illuminates when the unit is in operation. It flashes if there is an error in the unit or if firmware is not correct. It also flashes when you update firmware

6. CLEANING

The front panel should not be cleaned with dissolvent or abrasive substances because silk-printing could be damaged. To clean it, use a soft cloth slightly wet with water and neutral liquid soap; dry it with a clean cloth. Be careful that water never gets into the unit through the holes of the front panel.

7. FUNCTION LIST

1. Input signal indicators, INPUTS
2. Output signal indicators, OUTPUTS
3. Data traffic indicator, DATA
4. Power on indicator, POWER
5. Signal output screw terminal, OUT
6. Signal input screw terminal, IN
7. RJ-45 connector, ETHERNET
8. Screw terminals for digital remote control, REMOTE
9. Screw-assembled remote-control terminals via the TP-NET, RS-232 protocol
10. Screw terminals for continuous voltage control, GPI
11. Mains socket
12. Fuse holder
13. Power switch

8. FUNCTION DIAGRAMS

8.1 MIMO88SG

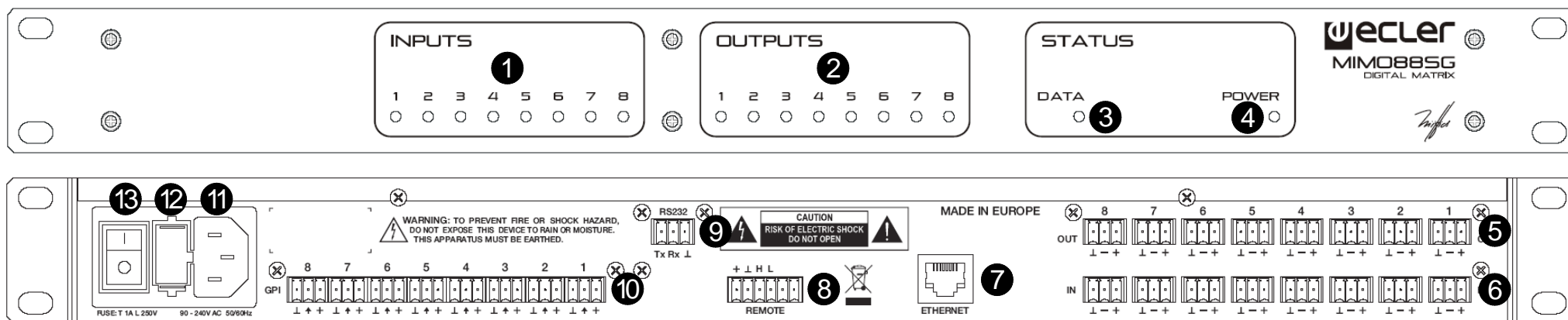

8.2. MIMO1212SG

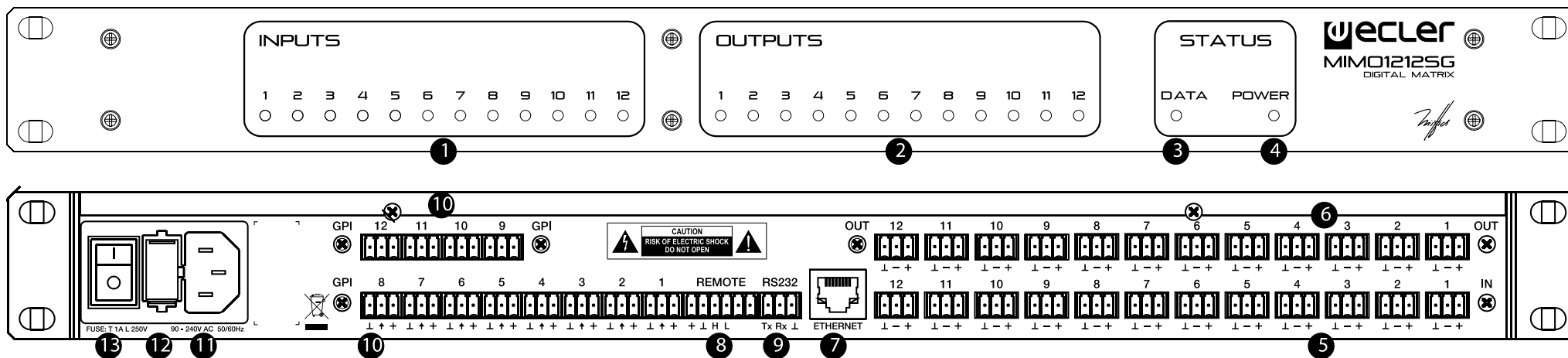

9. TECHNICAL CHARACTERISTICS

9.1. MIMO88SG

DSP

DSP	2x 32/64bit
Sampling Rate	48kHz
Latency IN to OUT	<2.9ms

Converters

Resolution	24bit AKM
Dynamic Range	AD:110dB, DA: 115dB

Analog

8 Input/Output	Terminal block (Symmetrical)
Analog Input headroom	+27dBV = +30dBu
Max. output level	+18dBV = +21dBu
Input sensitivity @ 0dBV out	From -50dBV to +10dBV in 0.5dB step
Input Impedance	Balanced, >4k Ω
Phantom power	+42VDC, 5mA max. software switched
Frequency response (-3dB)	5Hz to 24kHz
Flatness	better than ± 0.1 dB
THD+Noise @ 1kHz, 0dBV input (line)	<0.004%
THD+Noise @ 1kHz, -40dBV input (mic.)	<0.008%
Output Noise floor FFT (20Hz - 20kHz)	better than 115dB
Interchannel crosstalk (20Hz - 20kHz)	better than 90dB (100dB typ.)
Channel Leakage (20Hz - 20kHz)	better than 100dB (115dB typ.)

CMRR 20Hz- 20kHz

65dB typ.

Processing

Input Level (x8)

Range: from Off to 0 dB

Mute: Yes

Signal Polarity reverse: Yes

Metering: VU+clip pre & post fader

Output Level (x8)

Range: from Off to 0 dB

Mute: Yes

Solo: Yes

Signal Polarity reverse: Yes

Metering: VU+clip pre & post fader

Output Gain (x8)

Range: from 0 to +6 dB

Input Delay (x8)

from 0 to 1000 ms

Units: sec/ms/m/cm.

Output Delay (x8)

from 0 to 1000 ms

Units: sec/ms/m/cm.

Parametric Eq. Types

Bypass / On-Off all channels

(4 max per input)

Param Eq. Freq: 20Hz-20kHz;

(6 max per output)

Gain: -60/+12 dB

Q: 0.3 to 200

Low & High Shelf 6/12 dB/oct

Low & High Pass 6/12 dB/oct

All Pass 1/2 order

High & Low pass output Crossover filters (x8)	Bypass On-Off Butterworth in 6/12/18/24 dB/oct Bessel in 12/18/24 dB/oct Linkwitz-Riley in 12/24 dB/oct
Input Noise Gate (x8)	Bypass On-Off Threshold: from -80 dBV to +18 dBV Depth: 0 dB to 80 dB Attack time: from 0,1 ms. to 500 ms. Hold time: from 10 ms. to 3000 ms. Release time: from 10 ms. to 1000 ms.
Input Compressor / Limiter (x8)	Bypass On-Off Threshold: from -36 dBV to +18 dBV Ratio: 1:1 to inf:1 (limiter) Knee: hard / soft Attack time: from 0,1 ms. to 500 ms. Release time: from 10 ms. to 1000 ms. Make up gain: from 0 to +10 dB
Input Frequency Shifter (x4) (Feedback Loop Reducer)	Available on IN1 to IN4. ON / OFF function
Output Limiter (x8)	Bypass On-Off Threshold: from -36 dBV to +18 dBV Attack time: from 0,1 ms. to 500 ms. Release time: from 10 ms. to 1000 ms.

Built in Signal Generator

Sine: from 20 Hz to 20 kHz

Polarity: from 20 Hz to 20 kHz

White noise

Pink noise

Stereo Linking

Adjacent input / output channels

Linked processing

Matrix routing linked

Mix Matrix

Size: 8x8

Vol: Input, Output, Crosspoint

Mute: Set/Clear individual, row, column, all

Input /output Mono/stereo selector

Meter: Input /output VU and clip

Pager (x3)

Input: IN1 to IN8

Priorities: 3 (1 max, 3 min)

Depth: 0 dB to 80 dB

Attack time: from 5 ms. to 2000 ms.

Release time: from 50 ms. to 3000 ms.

Chime Source: None, Melody 1, Melody 2

Chime Volume: from -12 dB to 0 dB

Mechanical

Dimensions

482.6x44x266.5mm

Weight

3.5kg

Supply

Mains	90-264VCA 47-63Hz
Power consumption	45VA

Miscellaneous

Management Connectivity	Ethernet Base-Tx 10/100Mb Auto X-Over CAT5 up to 100m.
Remote Bus	over twisted pairs; up to 1km (see specific specs.)
GPI	8, from 0 to 10VDC or TTL level
Aux. Power Supply for Remotes & GPI	+12VDC, 1.2A. max. (short circuit protected)
Time and date retention (battery)	100 hours aprox. (ambient temperature dependant)
RTC accuracy	±1 minute / month

Software

EclerNet Manager	From v3.03r4 version.
------------------	-----------------------

9.2. MIMO1212SG

DSP

DSP	2x 32/64bit
Sampling Rate	48kHz
Latency IN to OUT	<3.2ms

Converters

Resolution	24bit AKM
Dynamic Range	AD:110dB, DA: 115dB

Analog

12Input/Output	Terminal block (Symmetrical)
Analog Input headroom	+27dBV = +30dBu
Max. output level	+18dBV = +21dBu
Input sensitivity @ 0dBV out	From -50dBV to +10dBV in 0.5dB step
Input Impedance	Balanced, >4k Ω
Phantom power	+42VDC, 5mA max. software switched
Frequency response (-3dB)	5Hz to 24kHz
Flatness	better than ± 0.1 dB
THD+Noise @ 1kHz, 0dBV input (line)	<0.004%
THD+Noise @ 1kHz, -40dBV input (mic.)	<0.008%
Output Noise floor FFT (20Hz - 20kHz)	better than 115dB
Interchannel crosstalk (20Hz - 20kHz)	better than 90dB (100dB typ.)
Channel Leakage (20Hz - 20kHz)	better than 100dB (115dB typ.)
CMRR 20Hz- 20kHz	65dB typ.

Processing

Input Level (x12)	<p>Range: from Off to 0 dB</p> <p>Mute: Yes</p> <p>Signal Polarity reverse: Yes</p> <p>Metering: VU + clip pre & post fader</p>
Output Level (x12)	<p>Range: from Off to 0 dB</p> <p>Mute: Yes</p> <p>Solo: Yes</p> <p>Signal Polarity reverse: Yes</p> <p>Metering: VU + clip pre & post fader</p>
Output Gain (x12)	Range: from 0 to +6 dB
Input Delay (x12)	<p>from 0 to 1000 ms</p> <p>Units: sec/ms/m/cm.</p>
Output Delay (x12)	<p>from 0 to 1000 ms</p> <p>Units: sec/ms/m/cm.</p>
Parametric Eq. Types	Bypass / On-Off all channels
(4 max per input)	Param Eq. Freq: 20Hz-20kHz;
(6 max per output)	Gain: -60/+12 dB
	Q: 0.3 to 200
	Low & High Shelf 6/12 dB/oct
	Low & High Pass 6/12 dB/oct
	All Pass 1/2 order
High & Low pass output Crossover filters (x12)	<p>Bypass On-Off</p> <p>Butterworth in 6/12/18/24 dB/oct</p> <p>Bessel in 12/18/24 dB/oct</p> <p>Linkwitz-Riley in 12/24 dB/oct</p>

Input Noise Gate (x12)

Bypass On-Off

Threshold: from -80 dBV to +18 dBV

Depth: 0 dB to 80 dB

Attack time: from 0,1 ms. to 500 ms.

Hold time: from 10 ms. to 3000 ms.

Release time: from 10 ms. to 1000 ms.

Input Compressor / Limiter (x12)

Bypass On-Off

Threshold: from -36 dBV to +18 dBV

Ratio: 1:1 to inf:1 (limiter)

Knee: hard / soft

Attack time: from 0,1 ms. to 500 ms.

Release time: from 10 ms. to 1000 ms.

Make up gain: from 0 to +10 dB

Input Frequency Shifter (x4)
(Feedback Loop Reducer)

Available on IN1 to IN4. ON / OFF
function

Output Limiter (x12)

Bypass On-Off

Threshold: from -36 dBV to +18 dBV

Attack time: from 0,1 ms. to 500 ms.

Release time: from 10 ms. to 1000 ms.

Built in Signal Generator

Sine: from 20 Hz to 20 kHz

Polarity: from 20 Hz to 20 kHz

White noise

Pink noise

Stereo Linking	Adjacent input / output channels Linked processing Matrix routing linked
Mix Matrix	Size: 12x12 Vol: Input, Output, Crosspoint Mute: Set/Clear individual, row, column, all Input /output Mono/stereo selector Meter: Input /output VU and clip
Pager (x3)	Input: IN1 to IN12 Priorities: 3 (1 max, 3 min) Depth: 0 dB to 80 dB Attack time: from 5 ms. to 2000 ms. Release time: from 50 ms. to 3000 ms. Chime Source: None, Melody 1, Melody 2 Chime Volume: from -12 dB to 0 dB

Mechanical

Dimensions	482.6x44x266.5mm
Weight	3.2kg

Supply

Mains	90-264VCA 47-63Hz
Power consumption	75VA

Miscellaneous

Management Connectivity	Ethernet Base-Tx 10/100Mb Auto X-Over CAT5 up to 100m.
Remote Bus	over twisted pairs; up to 1km (see specific specs.)
GPI	12, from 0 to 10VDC or TTL level
Aux. Power Supply for Remotes & GPI	+12VDC, 0,6A. max. (short circuit protected)
Time and date retention (battery)	100 hours aprox. (ambient temperature dependant)
RTC accuracy	±1 minute / month

Software

EclerNet Manager	From v3.03r4 version.
------------------	-----------------------

10. BLOCK DIAGRAMS

10.1. MIMO88SG

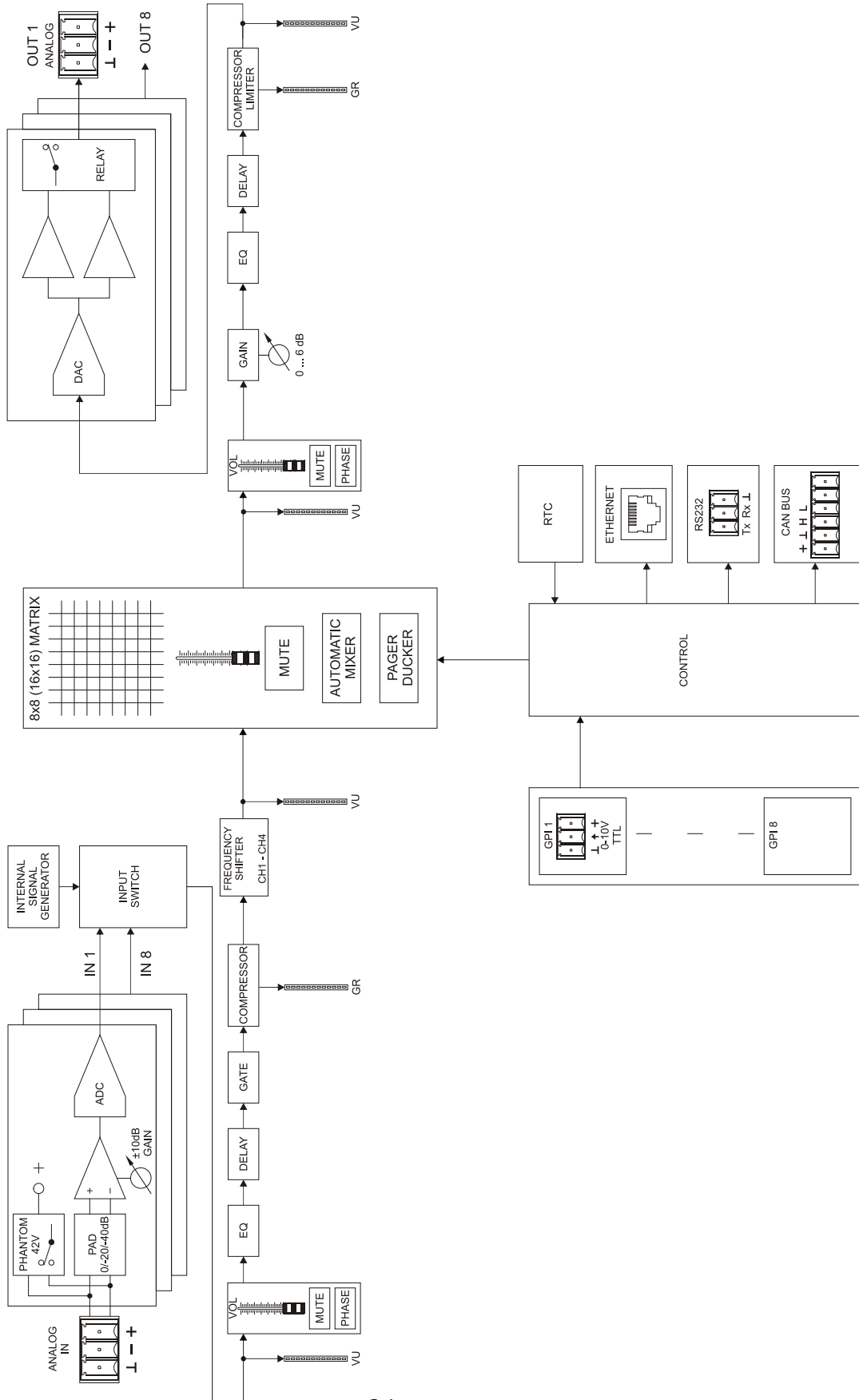

10.1. MIMO1212SG

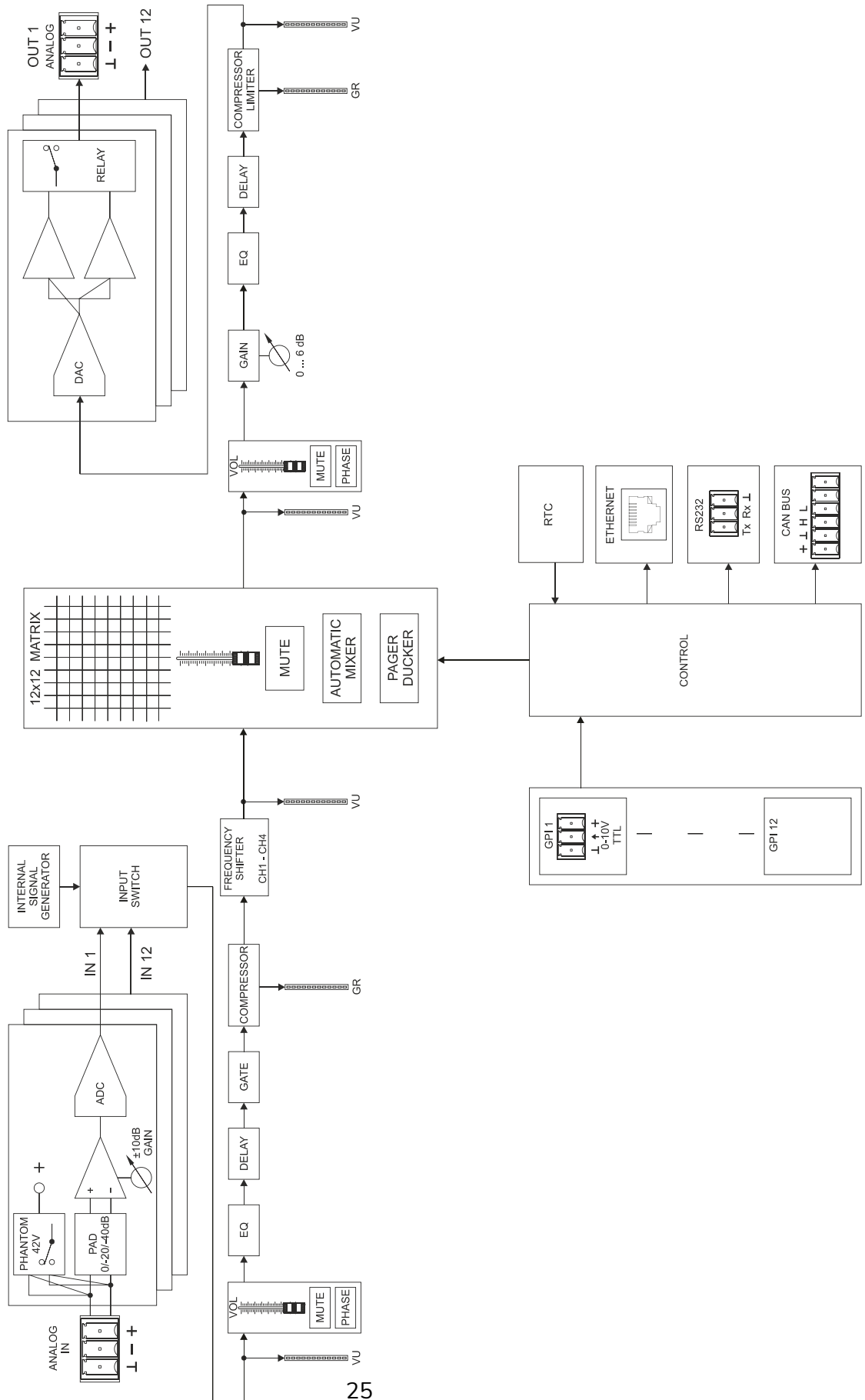

All product characteristics are subject to variation due to production tolerances. **NEEC AUDIO BARCELONA S.L.** reserves the right to make changes or improvements in the design or manufacturing that may affect these product specifications.

For technical queries contact your supplier, distributor or complete the contact form on our website, in [Support / Technical requests](#).

Motors, 166-168 08038 Barcelona - Spain - (+34) 932238403 | information@ecler.com | www.ecler.com