

MIMO7272DN

DIGITAL MATRIX

Digital Matrix with DANTE™/AES67 Interface



USER MANUAL

INDEX

1. IMPORTANT REMARK	3
2. IMPORTANT SAFETY INSTRUCTIONS.....	3
3. IMPORTANT NOTE.....	5
4. INTRODUCTION.....	5
4.1. <i>Main features.....</i>	6
5. INSTALLATION	7
5.1. <i>Location, assembly and ventilation.....</i>	7
5.2. <i>Mains connection and power on</i>	7
5.3. <i>Balanced analog audio inputs.....</i>	8
5.4. <i>Balanced analog audio outputs.....</i>	8
5.5. <i>Digital audio inputs and outputs over IP DANTE™/AES67</i>	9
5.6. <i>Programming and control Ethernet port</i>	11
5.6.1 <i>Factory Preset Network settings.....</i>	11
5.7. <i>Control remote RS-232 port.....</i>	11
5.8. <i>Remote control GPI ports.....</i>	12
5.9. <i>Remote control GPO ports.....</i>	13
6. OBSERVATIONS	13
6.1. <i>Ground loops.....</i>	13
6.2. <i>Background noise.....</i>	13
7. PACKAGE CONTENTS	14
8. FUNCTION LIST.....	14
9. FUNCTION DIAGRAM.....	15
10. BLOCKS DIAGRAM	16
11. TECHNICAL FEATURES.....	17

1. IMPORTANT REMARK

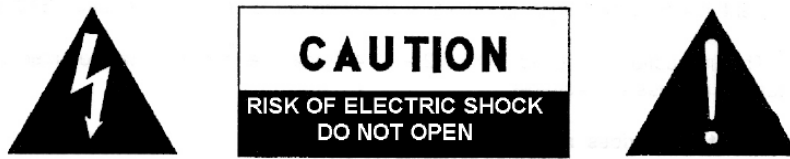

WARNING: SHOCK HAZARD - DO NOT OPEN

AVIS: RISQUE DE CHOC ÉLECTRIQUE - NE PAS OUVRIR



The lightning flash with arrowhead symbol, within an equilateral triangle, is intended to alert the user to the presence of uninsulated “dangerous voltage” within the product’s enclosure that may be of sufficient magnitude to constitute a risk of electric shock to persons.



The exclamation point within an equilateral triangle is intended to alert the user to the presence of important operating and maintenance (servicing) instructions in the literature accompanying the appliance.

WARNING (If applicable): The terminals marked with symbol of “” may be of sufficient magnitude to constitute a risk of electric shock. The external wiring connected to the terminals requires installation by an instructed person or the use of ready-made leads or cords.

WARNING: To prevent fire or shock hazard, do not expose this equipment to rain or moisture.

WARNING: An apparatus with Class I construction shall be connected to a mains socket-outlet with a protective earthing connection.

2. IMPORTANT SAFETY INSTRUCTIONS

1. Read these instructions.
2. Keep these instructions
3. Heed all warnings
4. Follow all instructions
5. Do not use this apparatus near water
6. Clean only with dry cloth
7. Do not block any ventilation openings Install in accordance with the manufacturer’s instructions

8. Do not install near any heat sources such as radiators, heat registers, stoves, or other apparatus (including amplifiers) that produce heat.
9. Do not defeat the safety purpose of the polarized or grounding type plug. A polarized plug has two blades with one wider than the other. A grounding type plug has two blades and a third grounding prong. The wide blade and the third prong are provided for your safety. If the provided plug does not fit into your outlet, consult an electrician for replacement of the obsolete outlet.
10. Protect the power cord from being walked on or pinched particularly at the plugs, convenience receptacles, and at the point where they exit from the apparatus.
11. Only use attachments/accessories specified by the manufacturer.
12. Unplug the apparatus during lightning sorts or when unused for long periods of time.
13. Refer all servicing to qualified personnel. Servicing is required when the apparatus has been damaged in any way, such as power supply cord or plug is damaged, liquid has been spilled or objects have fallen into the apparatus, the apparatus has been exposed to rain or moisture, does not operate normally, or has been dropped.
14. Disconnecting from mains: switching off the POWER switch all the functions and light indicators of the amplifier will be stopped, but fully disconnecting the device from mains is done unplugging the power cord from the mains input socket. For this reason, it always shall remain readily operable.
15. Equipment is connected to a socket-outlet with earthing connection by means of a power cord.
16. The marking information is located at the bottom of the apparatus.
17. The apparatus shall not be exposed to dripping or splashing and that no objects filled with liquids, such as vases, shall be placed on apparatus.
18. External wiring shall be connected by a skilled person.

NOTE: *This equipment has been tested and found to comply with the limits for a Class A digital device, pursuant to part 15 of the FCC Rules. These limits are designed to provide reasonable protection against harmful interference when the equipment is operated in a commercial environment. This equipment generates, uses, and can radiate radio frequency energy and, if not installed and used in accordance with the instruction manual, may cause harmful interference to radio communications. Operation of this equipment in a residential area is likely to cause harmful interference in which case the user will be required to correct the interference at his own expense.*



WARNING: This product must not be discarded, under any circumstance, as unsorted urban waste. Take it to the nearest electrical and electronic waste treatment centre.

CAUTION. Battery included on this product. Pay attention to the following safety statements:

1. Replacing the wrong type of battery will invalidate the safety protection
2. Explosion may be caused by putting the battery into the fire or heating furnace, or disposing of the battery by mechanical extrusion or cutting
3. Placing the battery in an extremely high temperature environment with flammable liquid or gas can cause the battery to explode or leak.
4. The extremely low air pressure of combustible liquid and gas placed on the battery may cause the battery to explode or leak.

NEEC AUDIO BARCELONA, S.L. accepts no liability for any damage that may be caused to people, animal or objects due to failure to comply with the warnings above.

3. IMPORTANT NOTE

Thank you for choosing our MIMO7272DN digital audio matrix with DANTE™/AES67 interface. It is **VERY IMPORTANT** to carefully read this manual and to fully understand its contents before any connection in order to maximize your use and get the best performance from this equipment.

To ensure optimal operation of this device, we strongly recommend that its maintenance be carried out by our authorised Technical Services.

MIMO7272DN comes with a 3 years warranty.

4. INTRODUCTION

MIMO7272DN is a 72x72 digital audio matrix (72 inputs and 72 outputs) for installation, fully programmable through the EclerNet Manager application (*).

(*) Refer to the EclerNet Manager Application manual for more information. The EclerNet Manager application is available for download at www.ecler.com.

It has 8 analog audio inputs and 8 analog audio outputs, 64 digital audio inputs DANTE™/AES67 and 64 digital audio outputs DANTE™/AES67, with a 64x64 simultaneous input / output channels native matrix.

MIMO7272DN is only available with standard firmware, and not with CONFERENCE firmware (intended for conferencing applications). For this type of CONFERENCE application please check the MIMO4040CDN model in our [website](#).

4.1. Main features

- 8 balanced MIC/LINE analog audio inputs (42VDC phantom power independent per input channel). Euroblock connectors
- 8 balanced analog audio outputs Euroblock connectors
- 2 balanced MONITOR outputs Euroblock connectors rear panel + stereo jack front panel
- 64-channel digital audio inputs DANTE™/AES67
- 64-channel digital audio outputs DANTE™/AES67
- Allows the use of network redundancy for the transport of audio over IP (2 Ports DANTE™/AES67: primary & secondary)
- 8 control ports GPI (General Purpose Input)
- 8 control ports GPO (General Purpose Output)
- Ethernet control port, RJ45 connector (Compatible with EclerNet Manager, UCPs and TP-NET protocol)
- RS-232 control port, DB9 connector (for integration with third-party systems, via TP-NET protocol)
- Programming and remote management via Ethernet via EclerNet Manager application (either point-to-point, with direct CAT5/CAT6 cable, or from an Ethernet network connection)
- Remote control via custom control panels UCP (User Control Panels)
- iOS and Android remote control app available (Ecler UCP V2)
- Remote control from third party external devices. (Crestron, AMX, Extron, Medialon, etc., are registered brands from their respective owners). TP-NET protocol, through Ethernet or RS-232 ports
- Remote control via panels and digital consoles connected to the same Ethernet network (WPNET and PAGENETDN series)
- Embedded UCP panel server: EclerNet projects executed in the internal matrix engine, acting as UCP server and as *hardware* control included in the project.
- Configuration memory management (presets).
- Events scheduled on a calendar basis
- Broad DSP processing configurable. Examples:
 - Matrix router-mixer, from any input to any output (analog and/or digital DANTE™/AES67) with adjustable crosspoint level (independent mixes of different inputs for each output).
 - Treatment of channels in mono or stereo mode.
 - Level, mute, vumeters and phase adjustment in inputs and outputs.
 - Internal signal generator (sinusoidal signal, pink noise, white noise, polarity test).
 - Parametric EQ on inputs and outputs.
 - Delays on inputs and outputs.

- Noise gate / compressor on input channels.
- Compressor / limiter on outputs.
- Priorities (ducking) between input channels.
- Virtual and physical paging consoles

The programming of MIMO7272DN is done using the EclerNet Manager application (*). Refer to the EclerNet Manager Application manual for more information.

(*) The EclerNet Manager application is available for download at www.ecler.com.

5. INSTALLATION

5.1. Location, assembly and ventilation

MIMO7272DN has been specially designed to be placed in 19" rack structure, occupying one unit.

It is very important that, as a heat generating element, MIMO7272DN is not completely enclosed or exposed to extreme temperatures. Fresh air should be allowed to pass through the ventilation holes in the chassis, leaving at least one free rack unit between each piece of equipment and those installed above and below it in the rack frame.

If the installation consists of several amplifiers in the same rack or is carried out inside cabinets closed by means of doors, it is highly recommendable to equip them with forced upward ventilation, installing fans at their lower and upper ends. This upward flow of ventilation will favour the dissipation of the heat generated in its interior.

5.2. Mains connection and power on

MIMO7272DN operates on alternating voltages from 90 to 264V and 47 to 63 Hz. This device is equipped with an oversized power supply capable of adapting without any type of adjustment to the mains voltage of any country in the world.

On the rear panel, next to the IEC power connector, there is an on/off switch for the unit. On the front panel there is an LED indicator that illuminates when the unit is in operation.

Do not allow the network cable to run parallel to the shielded cables carrying the audio signal, as this may cause humming.

5.3. Balanced analog audio inputs

MIMO7272DN has on its rear panel 8 analog signal inputs (IN 1 to 8), balanced and supporting line or microphone levels. The selection of the input signal type and its management is done from the EclerNet Manager application. Refer to the EclerNet Manager Application manual for more information.

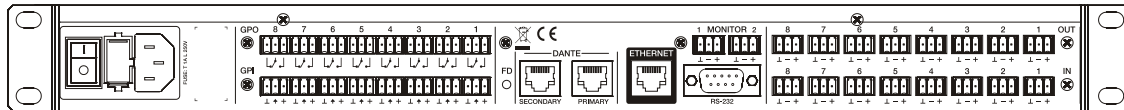

The signal input connectors are Euroblock type. The assignment of the connection is as follows:

Live or direct signal	>	Terminal +
Cold or inverted signal	>	Terminal -
Ground	>	Terminal ⊥

For UNbalanced connections, short-circuit the terminal - to earth.

5.4. Balanced analog audio outputs

The rear panel of the MIMO7272DN has 8 analog signal outputs (OUT 1 to 8) and 2 additional "MONITOR" monitoring outputs, balanced and with line level.

The signal output connectors are Euroblock type. The assignment of the connection is as follows:

Live or direct signal	>	Terminal +
Cold or inverted signal	>	Terminal -
Ground	>	Terminal ⊥

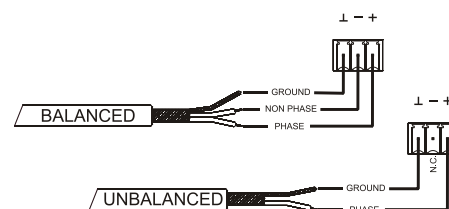

For UNbalanced connections, leave the terminal - unconnected.

5.5. Digital audio inputs and outputs over IP DANTE™/AES67

(Ports for primary and secondary networks)

MIMO7272DN allows the reception of 64 channels of digital audio DANTE™/AES67 and the sending of 64 channels of digital audio DANTE™/AES67 through an Ethernet network compatible with the transport of digital audio over IP through the DANTE™/AES67 protocol.

The routing of the digital audio signals DANTE™/AES67 through the Ethernet network, as well as the network configuration of the ports DANTE™/AES67 (IP addresses, mask, etc.) of the MIMO7272DN, is managed by the software application Dante Controller. For more information, please refer to the developer's documentation:

<https://www.audinate.com/products/software/dante-controller>

MIMO7272DN features two ports with RJ45 interface in its rear panel that allow the sending and reception of digital audio DANTE™/AES67, labelled as primary (PRIMARY) and secondary (SECONDARY). MIMO7272DN can work with these ports in two possible modes:

- **Redundant Mode:** there are two simultaneous network connections (each with its own IP address, both different) so that the information Ethernet packets DANTE™/AES67 are transmitted via both connections. Each port (primary and secondary) must be connected to a different physical Ethernet local network, or to a different virtual local network (VLAN), correctly configured and isolated from each other. The digital audio DANTE™/AES67 is therefore sent and received using two distinct and independent paths, with no possible communication between the primary and secondary ports. In case one of them fails, MIMO7272DN will automatically switch to the other, recovering the audio transmission almost instantaneously. Obviously, to achieve total redundancy, all DANTE™/AES67 devices that are part of a system of this type must have primary and secondary DANTE™/AES67 ports, connected respectively to the same two independent networks as MIMO7272DN.

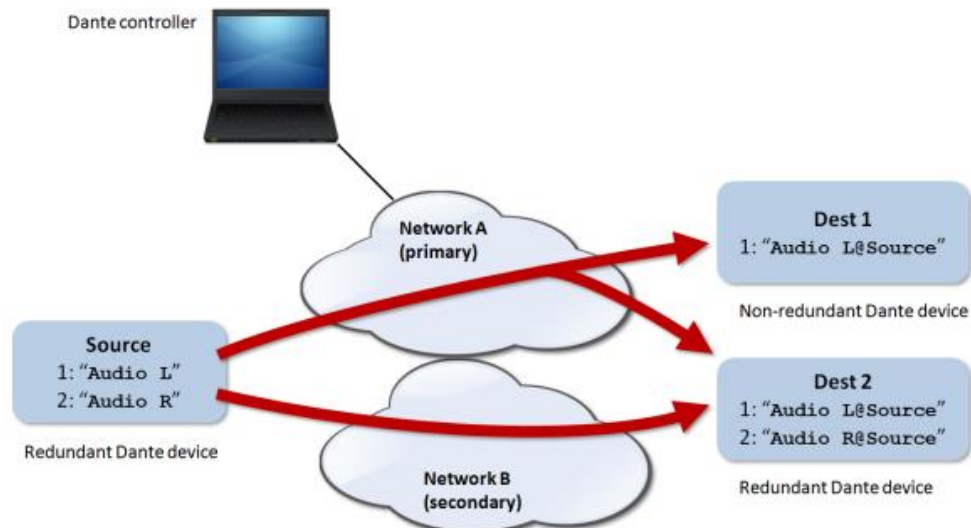

Note: in this mode, if (by mistake) the primary and secondary ports connect to the same Ethernet network, Dante Controller will no longer have access to the network configuration control and routing DANTE™/AES67 of the MIMO7272DN ports. This control is recovered when one of them is disconnected from the same network as the other.

Note: DANTE™/AES67 redundancy requires that the primary and secondary ports of all DANTE™/AES67 devices connect using the same network connection speed. For example, if the primary port connects to a network with a 1 Gbps link, the secondary port must also connect at 1 Gbps.

- **Switched mode:** in this mode, only a single network connection is actually enabled (and therefore only one IP address exists), with the primary and secondary ports behaving as ports of a network switch integrated within MIMO7272DN, to which devices forming part of the system's DANTE™/AES67 network, or Ethernet switches forming part of that network's infrastructure, can be directly connected.

Note: in this mode both ports primary and secondary, should never be connected simultaneously to network switches, as this would create a loop that would cause network conflicts and disruption of the digital audio DANTE™/AES67 traffic.

5.6. Programming and control Ethernet port

The RJ45 connector labelled ETHERNET allows the connection of the equipment to an Ethernet local network (LAN), being compatible with the following purposes:

- Management from the EclerNet Manager application, by direct connection (CAT5 cable or higher) of a computer with a MIMO7272DN unit or using an Ethernet network as a link between both. Refer to the EclerNet Manager Application manual for more information.
- Connection to third party control equipment. (Crestron, AMX, Extron, Medialon, etc. are registered brands from their respective owners). Protocol used: Ecler TP-NET. Refer to the TP-NET protocol manual for more information.
- UCP: EclerNet project remote control service using customisable graphical control panels. MIMO7272DN can act as a server for these panels, included in an EclerNet project, and also be remotely controlled by UCP panel client devices (WPNETTOUCH, Android® or iOS® mobile devices, Windows® devices, etc.).

5.6.1 Factory Preset Network settings

The factory default network settings for EclerNet Manager compatible devices are as follows:

- IP: 192.168.0.100
- Mask: 255.255.255.0
- Gate: 192.168.0.1
- UDP Port: 2210

5.7. Control remote RS-232 port

The RS-232 port with DB9 connector built into the rear panel allows an external device to communicate with a MIMO7272DN unit via serial connection. This connection will use the syntax of the TP-NET protocol so that the external device can obtain the value of some of the parameters of the MIMO7272DN unit (by means of "GET" commands) and/or modify these values ("SET" commands). Refer to the TP-NET protocol manual for more information.

The serial connection must comply with the following characteristics:

- Baud rate: 115200 (fixed, no auto negotiation)
- Data bits: 8
- Parity: None
- Stop bits: 1
- Flow control: None

5.8. Remote control GPI ports

The MIMO7272DN rear panel has 8 GPI inputs for direct voltage control, 0 to 10 VDC. Each of these inputs can be connected to an external physical device (a potentiometer, a contact closure, a variable 0-10V DC voltage, etc.) and associated with a MIMO7272DN function, for example:

- Remote control of an input channel volume, output or matrix crossover using a physical potentiometer or a remote control WPa series from Ecler
- Activation / deactivation of a MUTE or SOLO by means of a push-button or contact closure
- Retrieval of a *preset* by means of a pushbutton or contact closure

The GPI connectors are Euroblock type. The assignment of the connection is as follows

Positive, + 12 VDC	>	Terminal +
Variable voltage, 0-12 VDC	>	Terminal ↑
Ground	>	Terminal ⊥

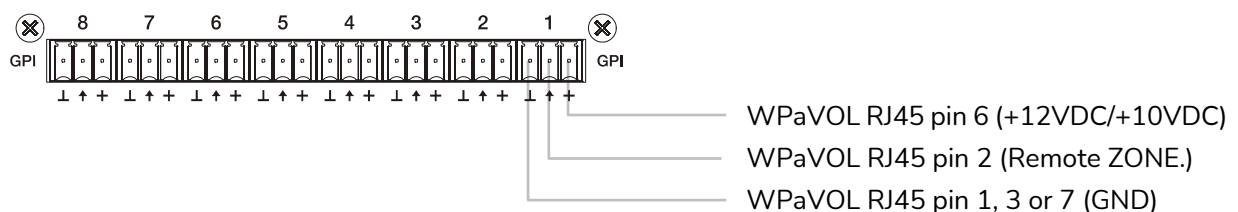

Jumpers position: ALOG / LIN → **LIN position**
 +12 / +10 → **+12 position**

WPaVOL connection to MIMO serial GPI ports

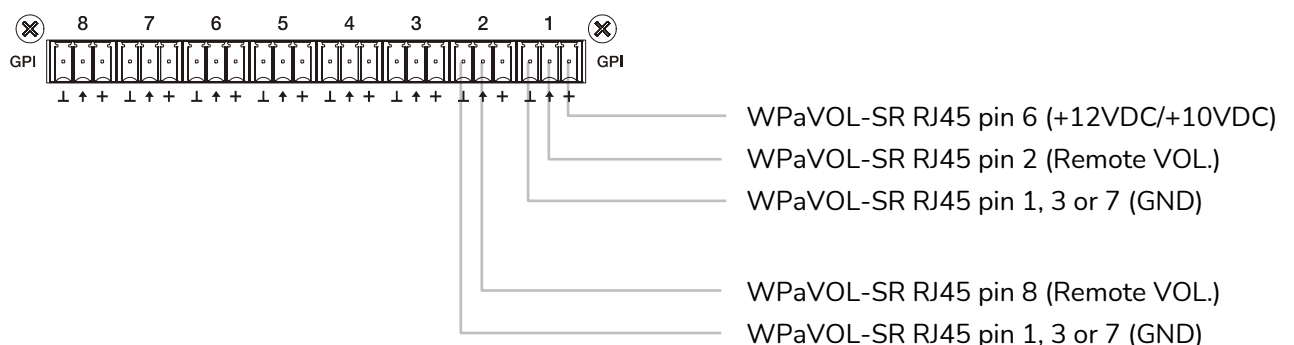

Jumpers position: ALOG / LIN → **LIN position**
 +12 / +10 → **+12 position**

WPaVOL-SR connection to MIMO serial GPI ports

The connection cables can be up to 500 meters approximately, using a minimum cross-section of 0,5 mm².

Consult your ECLER distributor or at www.ecler.com about the serial remote-control wall panels WPa series and other accessories available for connection to REMOTE / VCA ports.

5.9. Remote control GPO ports

MIMO7272DN has on its rear panel 8 relay outputs NO / NC (normally open / normally closed). Each of these outputs can have its status change associated with a trip by means of a specific function programmed through EclerNet Manager, such as a calendar event or the pressing of a key available on a UCP control panel. In this way, it is possible to interact with external equipment, such as motors for projection screens or movable partition walls, lights, sirens, GPI inputs from other equipment, etc.

6. OBSERVATIONS

6.1. Ground loops

It must be ensured at all times that the signal sources that reach the matrix, as well as all the devices that are connected to its output, do not have the grounds interconnected, that is to say that the grounds never reach them by two or more different paths, since, in this way, buzzes could be produced that would even interfere with the quality of the sound reproduction.

The shields of the cables, if they are connected to a chassis, must never be connected to each other. This way we avoid the formation of ground loops.

6.2. Background noise

MIMO7272DN has been designed to obtain the lowest possible background noise. Regardless of the electronic design, the background noise will depend directly on the correct use and installation of the unit.

It is not the same, for example, to have the GAIN control of a channel at 2 and the VOL of the output to which it is routed at maximum (case 1), to have a correct gain setting on the input signal and the VOL level of the output channels to which it is routed at an intermediate position (case 2). In the first case, the signal that reaches the mix amplifier,

which intrinsically has its own background noise level, is weak, so the signal-to-noise ratio is low (low signal). When the output amplifier raises indistinctly the whole set we will have a very high background noise level at the output.

In the second case, when the input gain is correctly adjusted, the signal received by the matrix is large and therefore with a large signal / noise ratio as well, so when this signal reaches the output channels and is amplified, it will have a better ratio than in the previous case.

7. PACKAGE CONTENTS

- MIMO7272DN
- AC power cables
- Euroblock aerial connectors for analog inputs and outputs and GPIO ports
- Quick User Guide and Warranty Card

8. FUNCTION LIST

1. Stereo jack headphone connection
2. Headphone volume control, VOL
3. Analog Input Signal LEDs, INPUTS
4. Analog output signal LEDs, OUTPUTS
5. Data traffic indicator light, DATA
6. Digital audio traffic light DANTE
7. Start-up indicator light, POWER
8. IEC type connector for external AC power cable
9. Fuse holder
10. Unit Power On Switch
11. Euroblock DC voltage control terminals, GPI
12. Euroblock relay output terminals, GPO
13. Ports DANTE primary and secondary, RJ-45 connector
14. Ethernet control port, RJ-45 connector
15. DB9 connector for remote control via TP-NET protocol, RS-232
16. Euroblock terminals analog audio output, MONITOR
17. Euroblock terminals analog audio output, OUT
18. Euroblock terminals analog audio input, IN

9. FUNCTION DIAGRAM

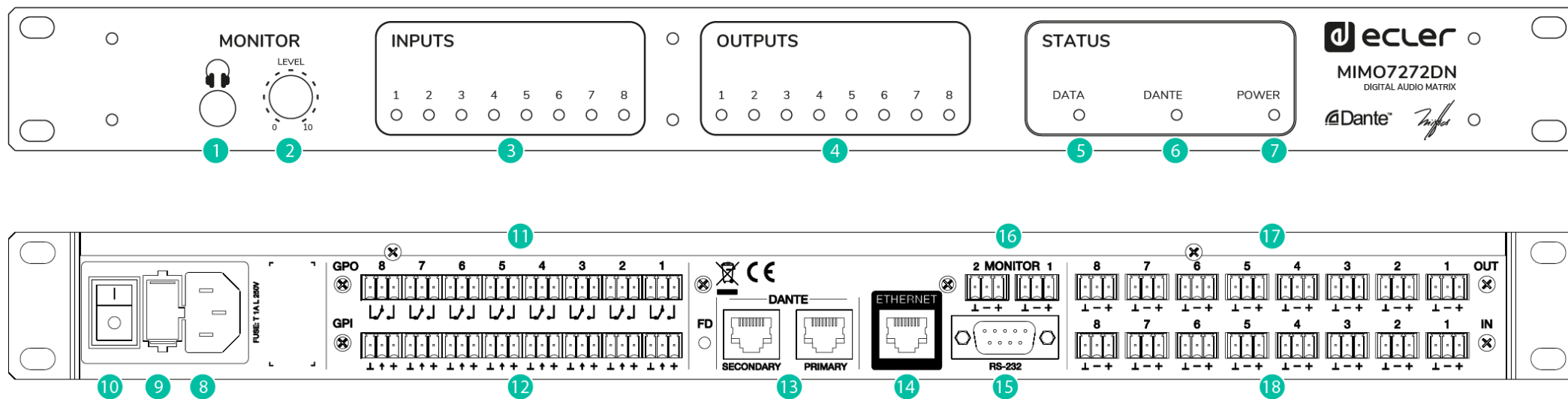

10. BLOCKS DIAGRAM

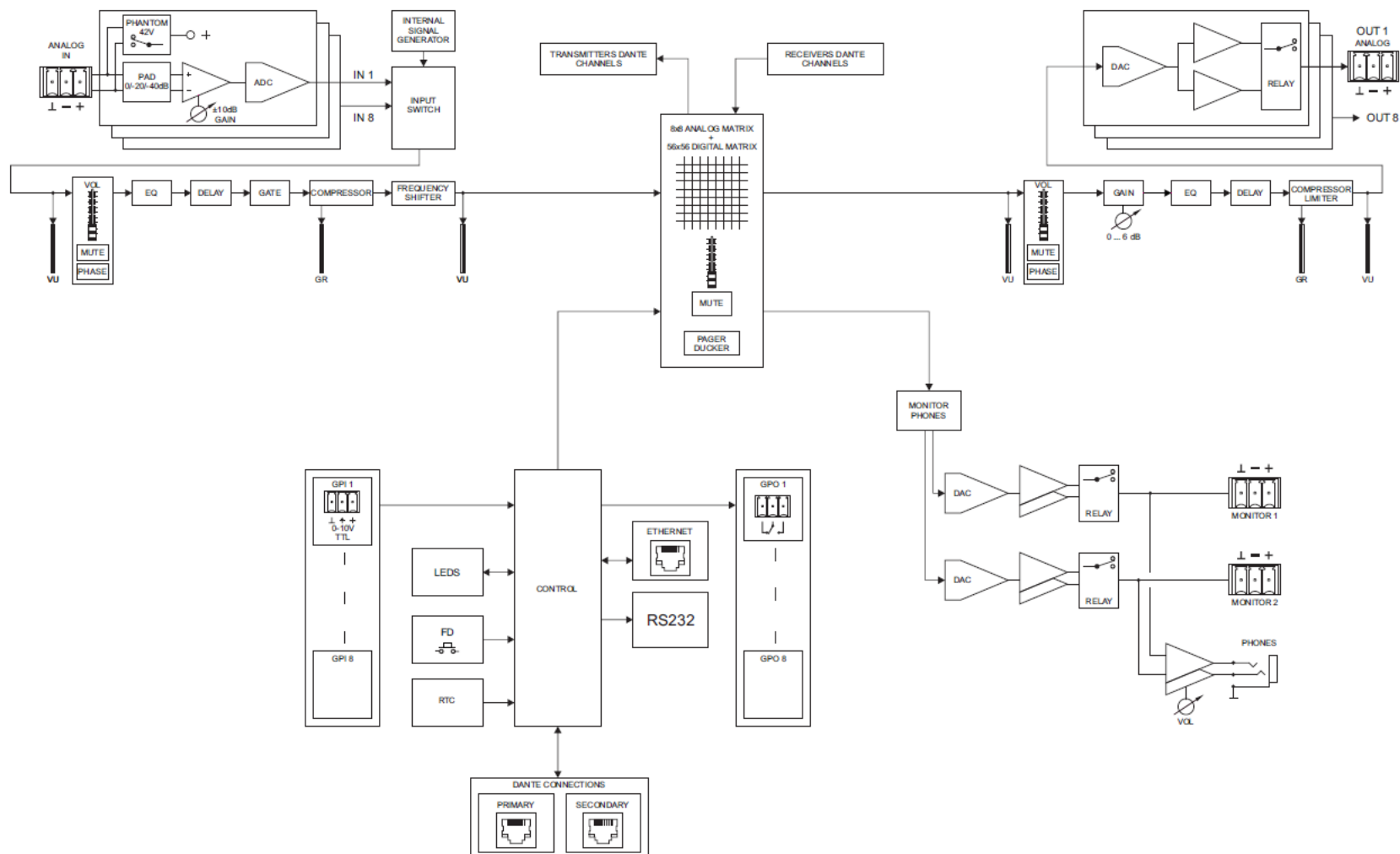

11. TECHNICAL FEATURES

MIMO7272DN	
DSP	
CPU	Quad core 64bits 1GHz
Sampling rate	48 kHz
Latency analog IN to analog OUT	<4.3 ms.
Converters	
Resolution	24 bit
Dynamic range	AD:110dB, DA: 115dB
Analogue	
8 Input / Output	Terminal block (Symmetrical)
2 monitor output	Terminal block (Symmetrical)
Headphones connector	Jack ¼
Analogue input headroom	+27dBV = +30dBu
Max. output level	+18dBV = +21dBu
Input sensitivity @0dBV out	from -50dBV to +10dBV in 0.5dB steps
Input impedance	Balanced, >4kΩ
Phantom power	+42VDC, 5mA max. software switched
Headphones	>200mW/200Ω
Frequency response (-3dB)	5Hz to 24kHz
Flatness	better than ±0.1dB
THD+Noise @ 1kHz, 0dBV input (line)	<0.004%
THD+Noise @ 1kHz, -40dBV input (mic.)	<0.008%
Output Noise floor FFT (20Hz - 20kHz)	better than 115dB
Interchannel crosstalk (20Hz - 20kHz)	better than 90dB (100dB typ.)
Channel Leakage (20Hz - 20kHz)	better than 100dB (115dB typ.)
CMRR 20Hz- 20kHz	65dB typ.
Dante™/AES67 Audio interface	
Dante™/AES67 Network Tx / Rx channels	64 / 64
Latency	1 / 2 / 5 ms (selectable)
Connector	1xRJ45 primary, 1xRJ45 secondary
Cable length between devices	100m CAT5e/CAT6

Processing	
Input level (x40)	Range: from Off to 0 dB Mute: Yes Signal Polarity reverse: Yes Metering: VU+clip pre & post fader
Output level (x40)	Range: from Off to 0 dB Mute: Yes Solo: Yes Signal Polarity reverse: Yes Metering: VU+clip pre & post fader
Output gain (x40)	Range: from 0 to +6 dB
Input delay (x40)	from 0 to 1000 ms. Units: sec/ms/m/cm.
Output delay (x40)	from 0 to 1000 ms. Units: sec/ms/m/cm.
Parametric EQ types (4max/input - 8max/output)	Bypass / On-Off all channels Param Eq. Freq: 20Hz-20kHz; Gain: -60/+12 dB Q: 0.3 to 200 Low & High Shelf 6/12 dB/oct Low & High Pass 6/12 dB/oct All Pass 1/2 order
High & Low pass output X-over filters (x40)	Bypass On-Off Butterworth in 6/12/18/24 dB/oct Bessel in 12/18/24 dB/oct Linkwitz-Riley in 12/24 dB/oct
Input noise gate (x40)	Bypass On-Off Threshold: from -80 dBV to +18 dBV Depth: 0 dB to 80 dB Attack time: from 0,1 ms. to 500 ms. Hold time: from 10 ms. to 3000 ms. Release time: from 10 ms. to 1000 ms.
Input compressor / limiter (x40)	Bypass On-Off Threshold: from -36 dBV to +18 dBV Knee: hard / soft Ratio: inf:1 (limiter) Attack time: from 0,1 ms. to 500 ms. Release time: from 10 ms. to 1000 ms. Make up gain: from 0 to +10 dB
Input Frequency Shifter (x40) (Feedback Loop Reducer)	Per input. ON / OFF function
Output Limiter (x40)	Bypass On-Off Threshold: from -36 dBV to +18 dBV Attack time: from 0,1 ms. to 500 ms. Release time: from 10 ms. to 1000 ms.
Built in Signal Generator	Sine: from 20 Hz to 20 kHz Polarity: from 20 Hz to 20 kHz White noise Pink noise
Stereo Linking	Adjacent input / output channels Linked processing Matrix routing linked

Mix Matrix	Size: 72x72 Analogue in/out 8x8 Dante/AES67 network in/out 32x32 Vol: Input, Output, Crosspoint Mute: Set/Clear individual, row, column, all Input/output Mono/stereo selector Meter: Input/output VU and clip
Pager (x10)	Input: IN1 to IN40 Priorities: 10 (1 max, 10 min) Depth: 0 dB to 80 dB Attack time: from 5 ms. to 2000 ms. Release time: from 50 ms. to 3000 ms. Chime Source: None, Melody 1, Melody 2 Chime Volume: from -12dB to 0dB
Mechanical	
Dimensions	482,6 x 44,0 x 266,5mm / 19.0"x 1.7" x 10,5"
Weight	3,25kg / 7.17 lb.
Power supply	
Mains	90-264VCA 47-63Hz
Power consumption	30VA
Miscellaneous	
Management Connectivity	Ethernet Base-Tx 10 /100Mb, 1GB Auto X-Over CAT5e or better
GPI	8, from 0 to 12VDC or TTL level
GPO	8, 3 poles isolated relay; 1A, 48VDC max.
Aux. Power Supply for Remotes & GPI	+12VDC, 1.2A max. (short circuit protected)
Time and date retention (battery)	> 3 months
Programming and control application	
EclerNet Manager	From v5.00



All product characteristics are subject to variation due to production tolerances. **NEEC AUDIO BARCELONA S.L.** reserves the right to make changes or improvements in the design or manufacturing that may affect these product specifications.

For technical queries contact your supplier, distributor or complete the contact form on our website, in [Support / Technical requests](#).

Motors, 166-168 08038 Barcelona - Spain - (+34) 932238403 | information@ecler.com | www.ecler.com