

## ePHS20T

### SPECIALIZED LOUDSPEAKERS

#### *Public Address Loudspeaker Cabinet*



### PRODUCT OVERVIEW

ePHS20T, is a horn loudspeaker carefully selected for the most extended 70V/100V paging and background music applications, offering durability and optimal speech and music reproduction. Manufactured in reinforced ABS and IP65 rated, therefore suitable for outdoor superior performance.

### KEY FEATURES

- ABS weatherproof horn loudspeaker
- 20 W RMS @ 8 ohms
- IP65
- Power tapings for 70V and 100V

### APPLICATIONS

- General paging and background music reproduction in 70V/100V installations

### MECHANICAL DIAGRAMS

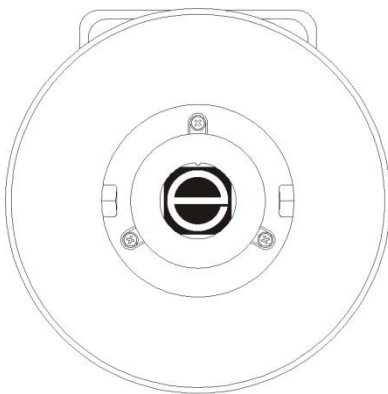

FRONTAL

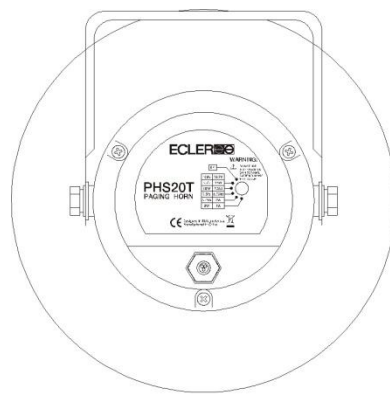

REAR

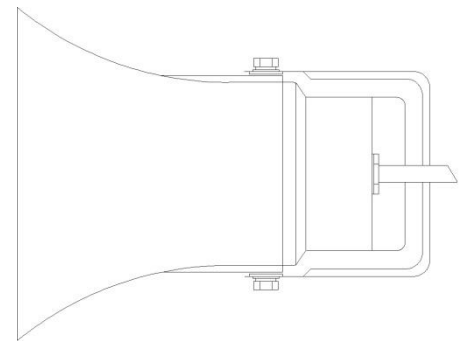

LATERAL

### TECHNICAL DATA

<b>Frequency response (-6dB)</b>	300 Hz ÷ 8 kHz
<b>Sensitivity</b>	102 dB ±3 dB
<b>Rated power</b>	20 W
<b>Power taps</b>	15, 7.5, 3.75, 2 W
<b>Line voltage</b>	100 V / 70
<b>Dimensions (mm)</b>	200 x 233
<b>Material</b>	ABS
<b>Finished color</b>	Grey (RAL 7035)
<b>Weight</b>	1.3 kg