

eMSP50T

SPECIALIZED LOUDSPEAKERS

Public Address Loudspeaker Cabinet



PRODUCT OVERVIEW

eMSP50T is a weather-proof 2-way musical horn carefully selected for the most extended 70V/100V paging and background music applications, offering durability and optimal speech and music reproduction. Manufactured in reinforced ABS and IP65 rated, therefore suitable for outdoor superior performance in music high-quality applications.

KEY FEATURES

- ABS weatherproof two way musical horn
- 50 W RMS @ 8 ohms
- IP65
- Power tapings for 70V and 100V

APPLICATIONS

- General paging and background music reproduction in 70V/100V installations

MECHANICAL DIAGRAMS

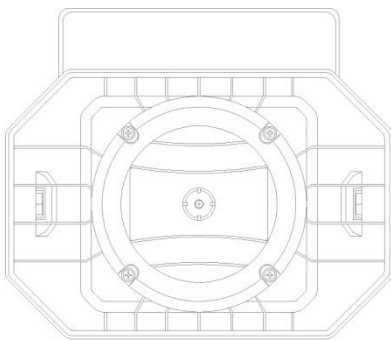

FRONTAL

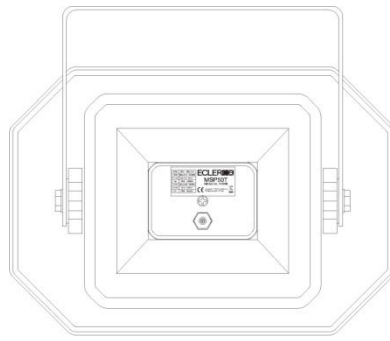

REAR

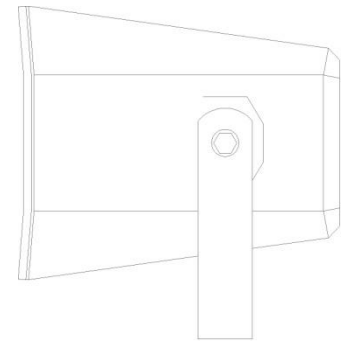

LATERAL

TECHNICAL DATA

Frequency response (-6dB)	70 Hz ÷ 20 kHz
Sensitivity	99 dB ±3 dB
Rated power	50 W
Power taps	50, 25, 12.5, 9, 4.5, 3.5 W
Line voltage	100 V / 70
Dimensions (mm)	250 x 360 x 320
Material	ABS
Finished color	White
Weight	3.9 kg