

## IC3

### CEILING LOUDSPEAKERS

*In-ceiling / In-wall Loudspeaker*



### PRODUCT OVERVIEW

IC3 is an in-ceiling installation loudspeaker with a great sound performance despite its compact design - halogen light shape. It features a 3" driver, 10 WRMS @ 8 ohm nominal power and 70/100V line transformer with 1,5 / 3 / 6 W power connections. It performs an aluminum grill with a refined frame. Available in white and black.

IC series provide excellent sound quality thanks to their infinite baffle philosophy and a top-performance high frequency transducer.

### KEY FEATURES

- One-way ABS loudspeaker
- 10 WRMS @ 8  $\Omega$
- 3" woofer
- Built-in audio transformer for 70/100 V use
- Aluminium front grill
- Discreet frame
- Connection via terminal block
- Installation by spring clips (without tools)
- Available in black (RAL9004) or white (RAL9003) finish
- EASE Win file available



### APPLICATIONS

- Corporate and residential buildings
- Commercial premises
- Leisure centres
- Sound reinforcement in clubs, bars, etc.
- Health and sports centres
- Meeting and conference rooms
- 5.1 and 7.1 surround systems
- Auditoriums, museums

## TECHNICAL SPECIFICATIONS

## IC3

System	
Effective frequency range <sup>1</sup>	110 Hz – 20 kHz (-10dB)
Coverage angle <sup>2</sup>	140°
Power handling	10W RMS / 40W Peak
Sensitivity <sup>3</sup>	86dB (1W/1m)
Maximum SPL <sup>4</sup>	96dB continuous / 102dB peak
Power options	100V: 1,5 / 3 / 6 W and 8 ohm 70V: 0,75 / 1,5 / 3 W and 8 ohm
Recommended amplifier	20W
Transducers	
Driver	3" woofer
Nominal impedance	8Ω
Physical	
Connection type	Terminal block
Installation options	In-ceiling, in-wall
Grille material	Aluminium rust proof
Mounting system	Spring clips (installation without tools)
Finished color	Black (RAL 9004) or White (RAL 9003)
External diameter	105mm / 4.13"
Internal diameter	88mm / 3,46"
Recommended cut out diameter	90mm / 3.54"
Required depth	90mm / 3.54"
Ceiling thickness	No limit min 50mm / 1.96" max
Weight	0,5 kg. / 1.10 lb.
Pieces per box	2 units
Shipping dimensions(WxHxD)	120 x 130 x 230mm / 4.7" x 5.1" x 9.0"
Shipping weight	0,6 kg. / 4.18 lb.

<sup>1</sup>10dB below the sound pressure level at specified sensitivity

<sup>2</sup>6dB below the sound pressure level than that at the direction of maximum level, Max. angle between 1 kHz and 4 kHz.

<sup>3</sup>Measured on-axis, far field and referenced to 1 meter by inverse square law. Average from 100 Hz to 10 kHz.

<sup>4</sup>Calculated from sensitivity and power handling specifications, exclusive of power compression

FREQUENCY RESPONSE ON-AXIS

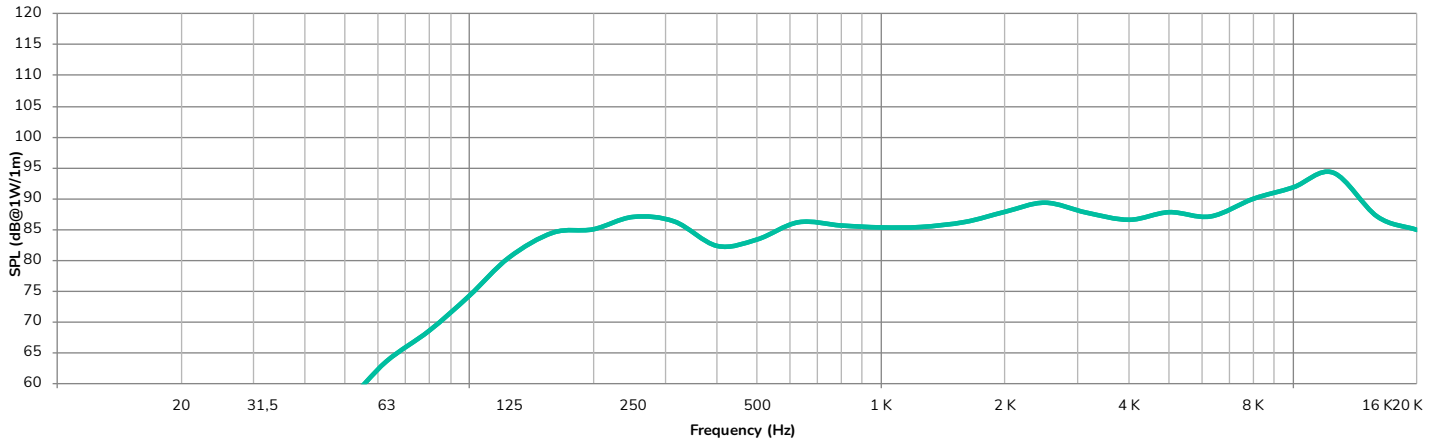

POLAR DIAGRAMS

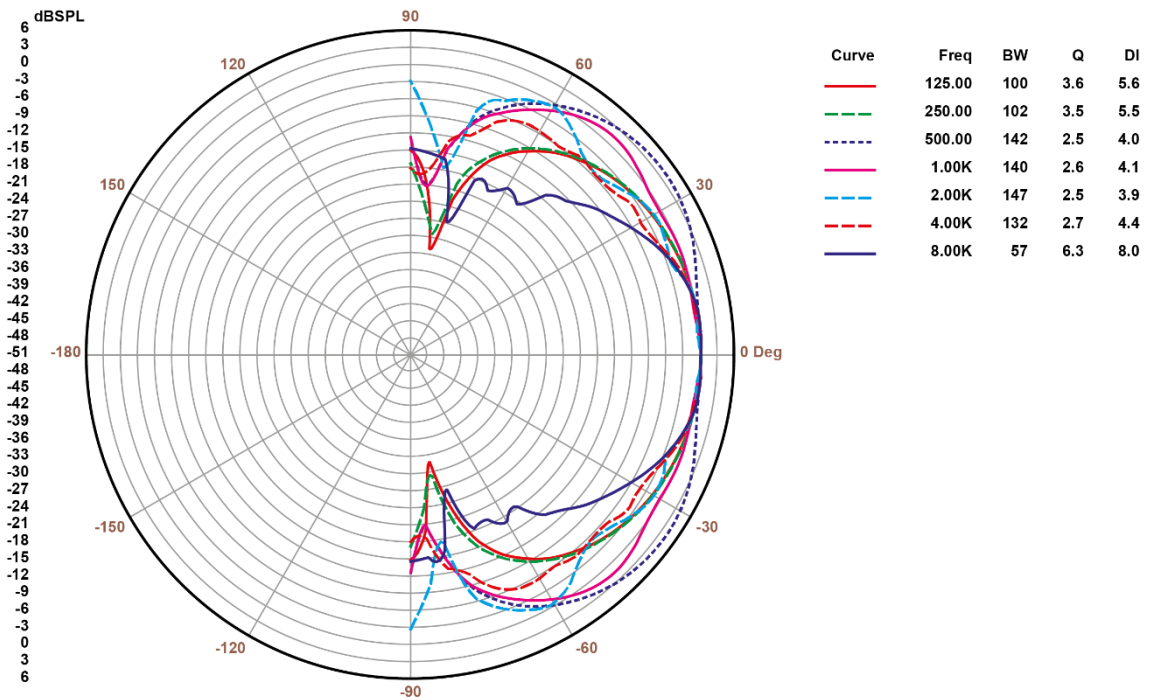

## MECHANICAL DIAGRAMS

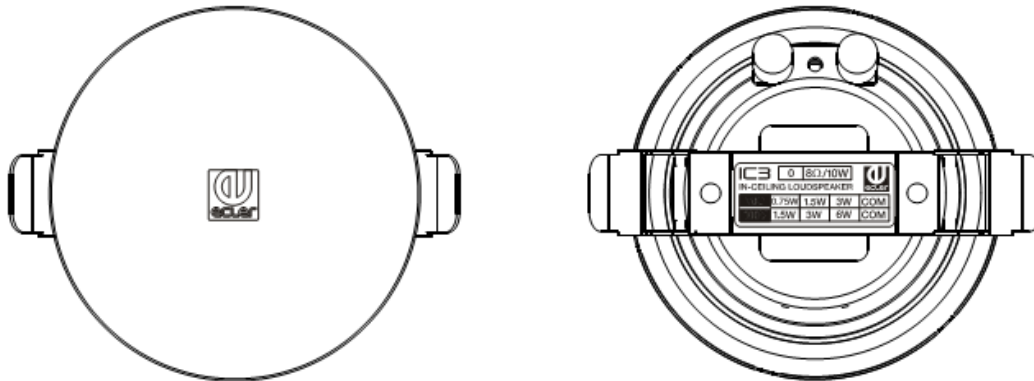

## A&E SPECIFICATIONS

The in-ceiling installation loudspeaker shall be a 1 way speaker, 3" woofer, suitable for 70/100 V line or low impedance installations. The power handling should be 10 W RMS at a rated impedance of 8  $\Omega$  with a peak power handling of 40 W. It shall include a line transformer with options for 1,5 / 3 / 6 W in 100V line and 0,75 / 1,5 / 3 W in 70V line, including an 8  $\Omega$  connection.

The effective frequency range shall be from 110 Hz to 20 kHz. The sensitivity shall be 86 dB, and the peak continuous sound pressure level shall be 96dB. The covered angle shall be 140°.

The enclosure shall be made of ABS plastic and the grill shall be made of rust proof aluminium. It shall come available in white (RAL9003) and black (RAL9005) colour. Mounting of the speaker into the ceiling shall be possible without tools using its spring clips. Connection to the amplifier shall be made via terminal block.

The loudspeaker shall have an external diameter of 105 mm, the required depth for installation shall be major than 90 mm and the weight shall not exceed 0'5 kg. The cut-out diameter shall be 90 mm. It shall be available data files that can be used with EASE and EASE ADDRESS acoustic simulation software.

The loudspeaker shall be the ECLER IC3.



All product characteristics are subject to variation due to production tolerances. **NEEC AUDIO BARCELONA S.L.** reserves the right to make changes or improvements in the design or manufacturing that may affect these product specifications.

For technical requests address to your supplier, distributor or fill the contact form in our website, at [Support / Technical Request](#).

Motors, 166-168 08038 Barcelona - Spain - (+34) 932238403 | [information@ecler.com](mailto:information@ecler.com) | [www.ecler.com](http://www.ecler.com)