

GLOBE

WISPEAK – WIRELESS PRO AUDIO

Rail-mount / Pendant Loudspeaker

WiSpeak



GLOBE (Rail-mount version)



GLOBE (Pendant version)

PRODUCT OVERVIEW

WiSpeak GLOBE is a 2-way self-powered sphere loudspeaker with wireless audio reception and control capabilities under the control of the Master unit. It includes a 5" woofer and a 1" silk dome tweeter. 360° horizontal dispersion. Available in two versions - with light-rail compatible installation system (RM) and pendant installation system (PD).

KEY FEATURES

- 32W RMS power rating
- Dispersion 360° x 160° (HxV)
- ABS reinforced with fibreglass
- RM version lighting rail mount compatible (Compatible light rails: 4 wire 3 circuit track system such as Global Track Pro, Eutrac or compatibles)
- PD version with 2 x 5m steel cords for pendant installation
- RM version with universal, internal power supply, taking mains AC from the lighting rail bracket (100-240VAC 50-60Hz)
- PD version with Euroblock power supply connection
- 1x WiSpeak wireless audio signal received, from the transmitter it is paired to
- Front panel UNPAIR control and LED indicators
- 12 meters maximum range, open space, for the WiSpeak wireless network (from the transmitter to each receiver)
- Available in white (RAL 9003) and black colour (RAL 9005)

APPLICATIONS

- Retail
- Hospitality
- Education
- Corporate
- Sports and wellness

ACCESSORIES AND COMPATIBLE DEVICES

- WiSpeak CORE



WiSpeak CORE

TECHNICAL SPECIFICATIONS

GLOBE

WiS (RF WIRELESS DIGITAL AUDIO)	
Frequency band	U-NII 5.1 – 5.8GHz (supported worldwide) Up to 24 non-overlapping RF channels DFS support"
Coverage range	Up to 12m from a TX to any paired RX, direct line of sight
Audio channels	1 mono audio ch received from the WiS TX network
Audio transmission	24bit uncompressed, 48kHz SR
Digital Audio Sample size	24bit
Digital Audio Sampling rate	48kHz
Digital Audio Frequency Response	20Hz – 20kHz (-0.1dB)
Digital Audio converters	DAC Resolution: 24 bit DAC Dynamic range: 100dB
Latency	From TX IN to RX AUX OUT <6ms From TX IN to RX Speaker <6ms Jitter among receivers ±1us
Pairing time	Up to 120s
Reconnection time	Up to 120s
System	
Effective frequency range ¹	78 Hz – 20 kHz (-10dB)
Coverage angle ²	111° (conical)
Sensitivity ³	91 dB (1W/1m)
Maximum SPL ⁴	106 dB Continuous / 112 dB Peak
Transducers	
Ways	2-ways full range
Driver	5" woofer + 1" tweeter
Low frequency driver	5" woofer
High frequency driver	1" Silk Dome Tweeter
Crossover filter	4.2KHz
Nominal impedance	8Ω
Powered	
Power	32W RMS / 128W peak
THD + Noise	<0,15%
Signal Noise Ratio	>95dB
Electrical	
Power supply	Internal. Universal, regulated switch mode with PFC (Power Factor Correction)
AC mains requirement	100-240 VAC @ 50-60Hz
AC mains connector	Ceiling rail connection for GLOBE RM Series 3C Euroblock connector for GLOBE PD Series
Power consumption	TBC

Physical	
Connection type	Ceiling rail AC connection for GLOBE RM Series Euroblock 3C connector for VAC in GLOBE PD Series
Installation options	Rail Mount / Pendant options
Environmental	IP10
Certifications	TBC
Enclosure material	ABS reinforced with fibreglass
Rail fixing system	4 wire 3 circuit track system for GLOBE RM
Compatible rail systems	Global Track Pro or compatibles for GLOBE RM
Operating temperature	Min: 0°C ; 32°F / Max: 35°C ; 95°F
Operating humidity	<85% HR
Storage temperature	Min: -10°C ; 14°F / Max: 50°C ; 122°F"
Storage humidity	<90% HR
External diameter	287 mm / 11.3"
Included accessories	For GLOBE PD Series: 2 x Steel Wire for hanging 5 mts, 2x plastic cable tie, 1 x eurobloc 3C connector
Finished colour	White (RAL 9003) or black (RAL 9005)
Dimensions	Ø287mm x 331mm(H) / Ø11.3 in. x 13 in. (H)
Weight	2.2 Kg / 4.85 lbs
Pieces per box	1
Shipping dimensions	360 x 480 x 360 mm / 14.2 x 18.9 x 14.2 in. (WxHxD)
Shipping weight	3.7 Kg / 8.15 lb

¹10dB below the sound pressure level at specified sensitivity

²6dB below the sound pressure level than that at the direction of maximum level, Max. angle between 1 kHz and 4 kHz.

³Measured on-axis, far field and referenced to 1 meter by inverse square law. Average from 100 Hz to 10 kHz.

⁴Calculated from sensitivity and power handling specifications, exclusive of power compression

WiSpeak features a unique & intelligent digital wireless transmission system: a solid and stable main channel is always used for the system's audio and control links, together with an alternative backup channel available. The system continuously monitors among 24 transmission channels to resolve the best backup channel option. In case the main channel's integrity is affected by third-party RF interferences, an instantaneous and clean (free of audio drops) switch to the backup one is performed.

Exceptionally, when working in environments with very high radio-electric contamination (presence of frequency inhibitors, WiFi networks saturation, etc.) WiSpeak might at times suffer disturbances in its proper functioning, like intermittent audio drops. In such circumstances, and along the system's installation and setup period, it might even be necessary to decrease the distance from the transmitter to each receiver to reach a solid and stable system performance along time.

Reconnection and pairing time also involve stabilization process to guarantee a solid and stable wireless communication. This time varies depending on adverse conditions described.

FREQUENCY RESPONSE ON-AXIS

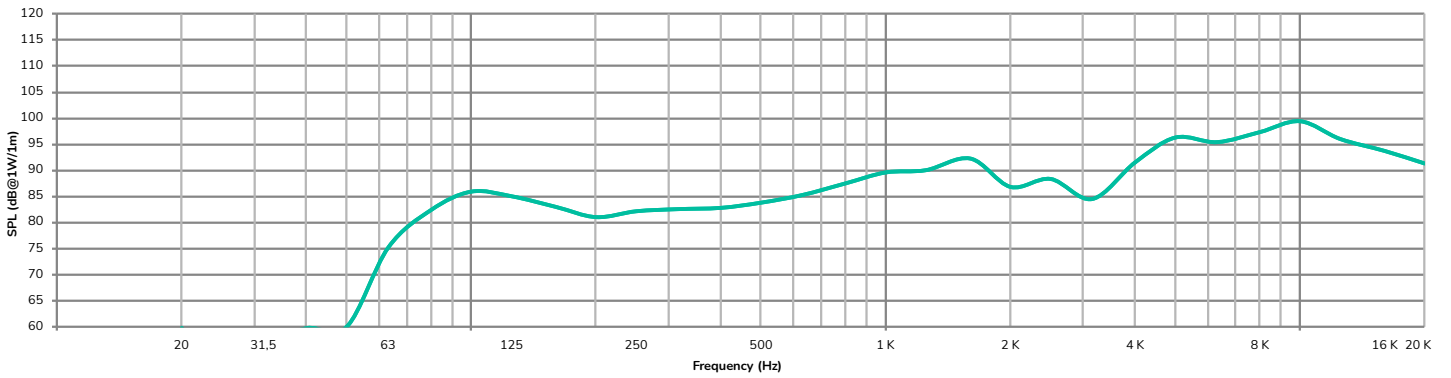

POLAR DIAGRAM

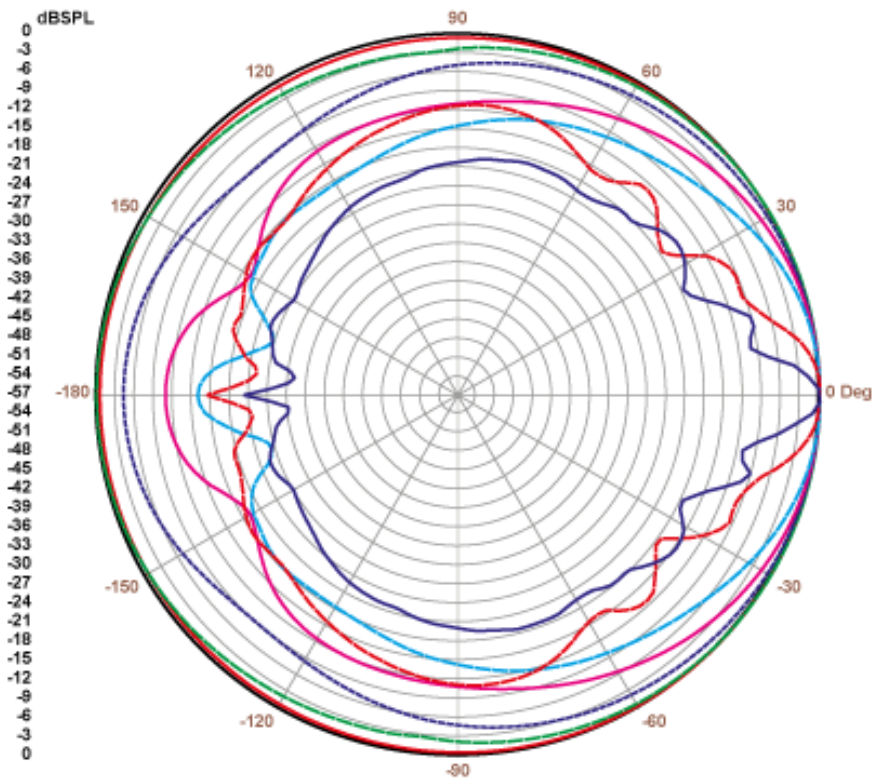

Curve	Freq	BW	Q	DI
—	125.00	360	1.0	0.0
—	250.00	360	1.0	0.0
- - -	500.00	195	1.8	2.7
—	1.00K	111	3.3	5.1
—	2.00K	74	4.8	6.8
—	4.00K	26	13.8	11.4
—	8.00K	10	35.8	15.5

MECHANICAL DIAGRAM

GLOBE Rail Mount Version

Distances are in millimeters.

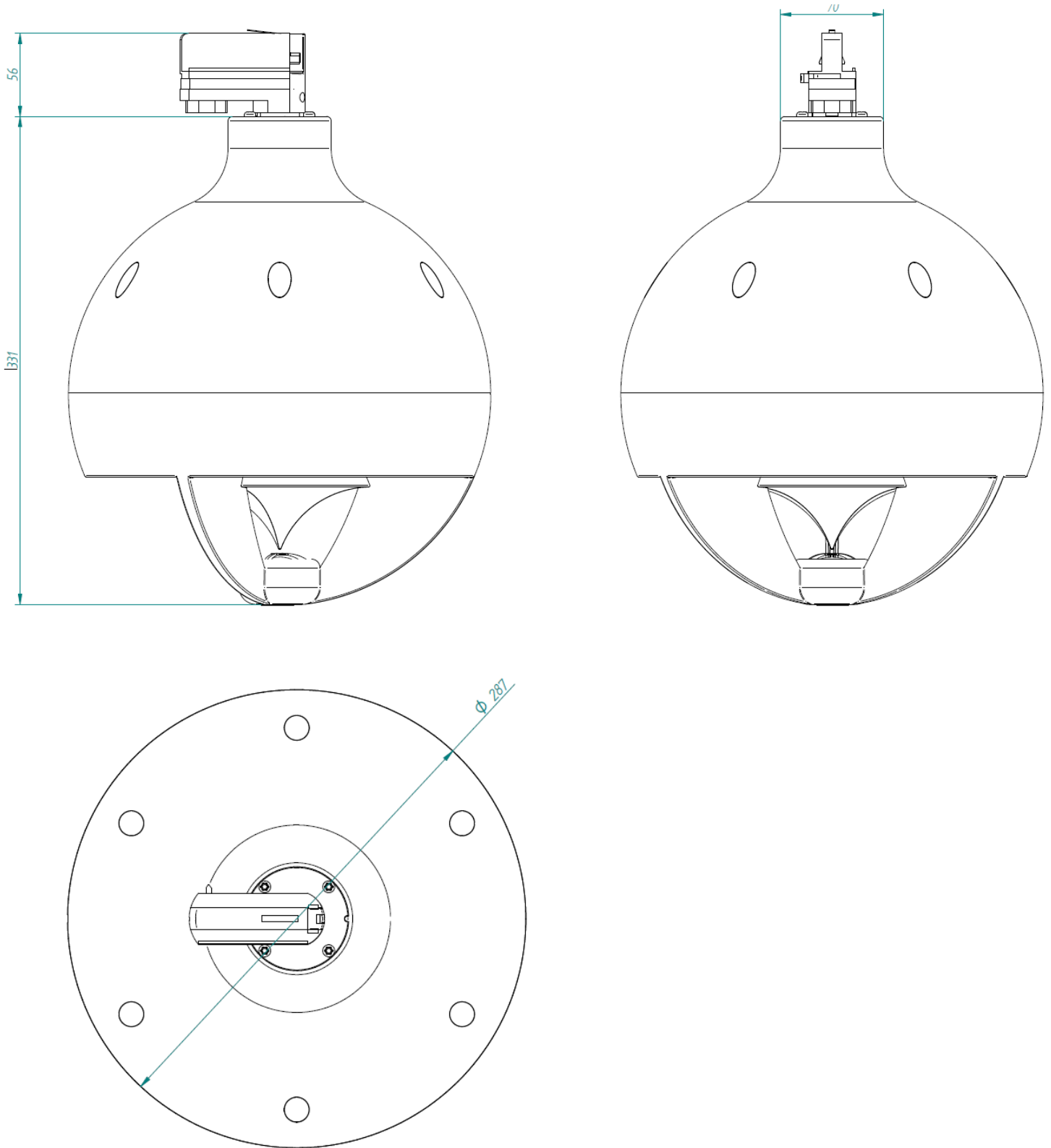

GLOBE Pendant Version

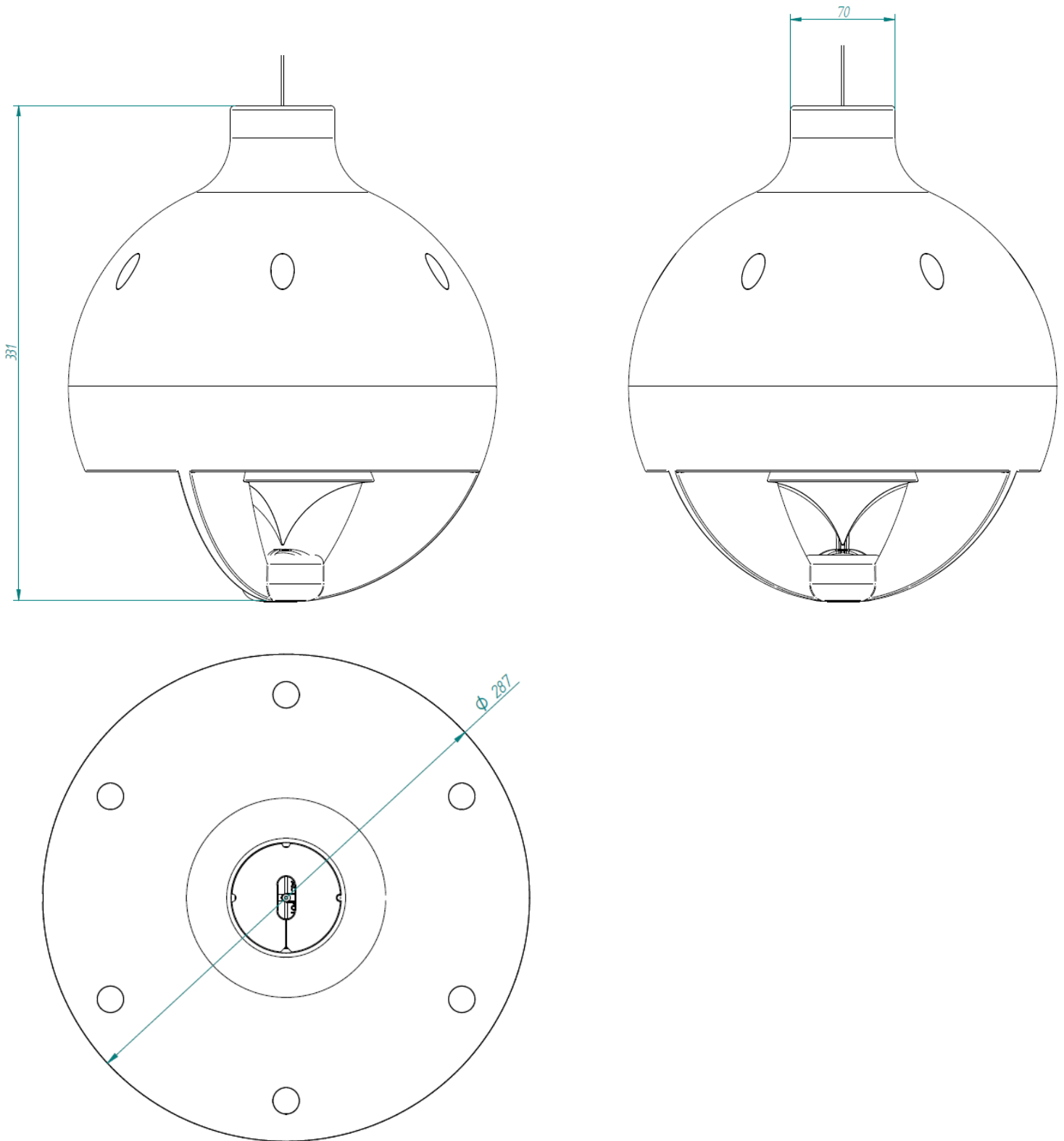

A&E SPECIFICATIONS

The receiver shall be a two-way self-powered sphere loudspeaker consisting of an 5" woofer and a 1" silk dome tweeter, lighting rail mount compatible (RM Version) or for pendant installation compatible (PD Version). The power handling should be 32 W RMS with a peak power handling of 128 W.

The effective frequency range (± 10 dB) shall be from 78 Hz to 22 kHz. The sensitivity shall be 91 dB considering 1 W input signal at 1 meter distance. The maximum continuous sound pressure level shall be 106 dB, while the maximum peak pressure level shall be 112 dB considering the loudspeaker's rated power. The coverage angle shall be a 111° conical coverage pattern.

The enclosure shall be made of ABS reinforced with fibreglass. It shall come available in both white (RAL9003) and black (RAL9005) colours. Mounting of the rail-mount speaker into the lighting rail shall be possible using the rail mount adapter compatible with light rails performing 4 wire 3 circuit track system such as Global Trac Pro, Eutrac or other compatible systems

Mounting of the pendant speaker into the ceiling shall be possible using the steel wire hanging. Connection shall be made via Euroblock 3C connector.

The loudspeaker shall have a diameter of 282 mm, a high of 331 mm and the weight shall not exceed 2,2 kg. It shall have data files available that can be used with EASE acoustic simulation software.

The loudspeaker shall be the ECLER WISPEAK GLOBE.

All product characteristics are subject to variation due to production tolerances. **NEEC AUDIO BARCELONA S.L.** reserves the right to make changes or improvements in the design or manufacturing that may affect these product specifications

For technical queries contact your supplier, distributor or complete the contact form on our website, in [Support / Technical requests](#).

Motors, 166-168 08038 Barcelona - Spain - (+34) 932238403 | information@ecler.com | www.ecler.com