

IW103

CEILING LOUDSPEAKERS

In-ceiling / In-wall High-end Loudspeaker



USER MANUAL

INDEX

1. IMPORTANT REMARK	3
2. IMPORTANT SAFETY INSTRUCTIONS	3
3. IMPORTANT NOTE	5
4. INTRODUCTION	5
5. MAIN CHARACTERISTICS:	5
6. CONNECTING.....	6
7. INSTALLATION.....	6
8. TECHNICAL SPECIFICATIONS.....	7
<i>Mechanical diagrams</i>	8

1. IMPORTANT REMARK



WARNING: SHOCK HAZARD - DO NOT OPEN
AVIS: RISQUE DE CHOC ÉLECTRIQUE - NE PAS OUVRIR



The lightning flash with arrowhead symbol, within an equilateral triangle, is intended to alert the user to the presence of uninsulated “dangerous voltage” within the product’s enclosure that may be of sufficient magnitude to constitute a risk of electric shock to persons.



The exclamation point within an equilateral triangle is intended to alert the user to the presence of important operating and maintenance (servicing) instructions in the literature accompanying the appliance.

WARNING (If applicable): The terminals marked with symbol of “” may be of sufficient magnitude to constitute a risk of electric shock. The external wiring connected to the terminals requires installation by an instructed person or the use of ready-made leads or cords.

WARNING: To prevent fire or shock hazard, do not expose this equipment to rain or moisture.

WARNING: An apparatus with Class I construction shall be connected to a mains socket-outlet with a protective earthing connection.

2. IMPORTANT SAFETY INSTRUCTIONS

1. Read these instructions.
2. Keep these instructions.
3. Heed all warnings.
4. Follow all instructions.
5. Do not use this apparatus near water.
6. Clean only with dry cloth.
7. Do not block any ventilation openings. Install in accordance with the manufacturer’s instructions.
8. Do not install near any heat sources such as radiators, heat registers, stoves, or other apparatus (including amplifiers) that produce heat.

9. Do not defeat the safety purpose of the polarized or grounding type plug. A polarized plug has two blades with one wider than the other. A grounding type plug has two blades and a third grounding prong. The wide blade or the third prong are provided for your safety. If the provided plug does not fit into your outlet, consult an electrician for replacement of the obsolete outlet.
10. Protect the power cord from being walked on or pinched particularly at the plugs, convenience receptacles, and at the point where they exit from the apparatus.
11. Only use attachments/accessories specified by the manufacturer.
12. Unplug the apparatus during lightning sorts or when unused for long periods of time.
13. Refer all servicing to qualified personnel. Servicing is required when the apparatus has been damaged in any way, such as power supply cord or plug is damaged, liquid has been spilled or objects have fallen into the apparatus, the apparatus has been exposed to rain or moisture, does not operate normally, or has been dropped.
14. Disconnecting from mains: When switching off the POWER switch, all the functions and light indicators of the unit will be stopped, but fully disconnecting the device from mains is done by unplugging the power cable from the mains input socket. For this reason, it always shall remain easily accessible.
15. Equipment is connected to a socket-outlet with earthing connection by means of a power cord.
16. The marking information is located at the bottom of the unit.
17. The apparatus shall not be exposed to dripping or splashing and that no objects filled with liquids, such as vases, shall be placed on apparatus.

NOTE: *This equipment has been tested and found to comply with the limits for a Class A digital device, pursuant to part 15 of the FCC Rules. These limits are designed to provide reasonable protection against harmful interference when the equipment is operated in a commercial environment. This equipment generates, uses, and can radiate radio frequency energy and, if not installed and used in accordance with the instruction manual, may cause harmful interference to radio communications. Operation of this equipment in a residential area is likely to cause harmful interference in which case the user will be required to correct the interference at his own expense.*



WARNING: This product must not be discarded, under any circumstance, as unsorted urban waste. Take to the nearest electrical and electronic waste treatment centre.

NEEC AUDIO BARCELONA, S.L. accepts no liability for any damage that may be caused to people, animal or objects due to failure to comply with the warnings above.

3. IMPORTANT NOTE

Thank you for choosing our Ecler **In ceiling / In-wall High-end Loudspeaker IW103!**

It is **VERY IMPORTANT** to carefully read this manual and to fully understand its contents before any connection in order to maximize your use and get the best performance from this equipment.

To ensure optimal operation of this device, we strongly recommend that its maintenance be carried out by our authorised Technical Services.

Ecler **IW103** comes with a **3-year warranty**.

4. INTRODUCTION

The IW103 loudspeaker for installation in the wall or ECLER ceiling, incorporates a careful selection of components, in an easy-to-use design to make installation swift. It also offers excellent sound reproduction in bass and treble thanks to its one-way system, a full-range 3" transducer.

The transformer housed inside makes it possible to use the unit intuitively on line with 100V/70V, simply by changing the position of the terminals.

The discrete rectangular design as well as the ease and speed of installation make the IW103 the ideal option for a wide range of applications and architectonic environments.

5. MAIN CHARACTERISTICS:

- Wall or false ceiling fitting Loudspeaker
- 3" woofer
- Connections for 15W/30W @ 100V spring-loaded terminal input connectors
- Sensitivity (1W/1m): 84 dB SPL
- Available in white (RAL 9003)
- Installation system: 2 points with rotating flange

Note: in the event of using in installations at 70V, the corresponding power ratings for the 100V position will be reduced to half those indicated on the switchboard. In the event of installations at 50V, it will be reduced to a quarter.

Model IW103 incorporates a detachable protective grille. Take care not to damage the loudspeaker when extracting the grille.

6. CONNECTING

The connection terminals are the crimp connector type for stripped wire. In areas where a low sound level is needed, use the terminals COM and 15W to connect the loudspeaker; while in areas where a higher sound level is required, use the terminals COM and 30W. At all times, respect the polarity.

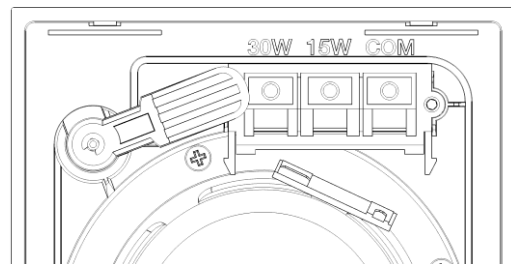

Note: If the system is accidentally connected at low impedance 8Ω , this will not cause any damage to the loudspeaker, but it will reduce its performance considerably below its capabilities.

It is easy to install each unit with the 2 rotating flanges included. For further details on the method of installing, please consult the section INSTALLATION in this manual.

7. INSTALLATION

To correctly install this product, it is essential to first make a rectangular hole in the place where it is to be fitted, allowing for the relevant wiring for each unit.

See below for details of the steps to follow for correct installation:

1. Remove the protective grille from the unit.
2. Make a rectangular hole in the false ceiling or wall. The dimensions needed for this hole are 147x95 mm.
3. Connect the existing wires into the installation with the unit using the crimp connectors.
4. Insert the loudspeaker into the hole. Hold the unit with one hand and insert it into position, ensuring that the 2 rotating flanges lie at a tangent to the cut.

5. Tighten the 2 screws accessible from the front part of the unit. The loudspeaker will then be fixed into its final position.
6. Place the protective grille.

8. TECHNICAL SPECIFICATIONS

IW103

System	
Effective frequency range ¹	83 Hz-20 kHz (-10dB)
Coverage angle ²	158°x158° (HxV)
Power handling	30 W RMS / 120 W Peak
Sensitivity ³	84 dB (1W/1m)
Maximum SPL ⁴	99 dB continuous / 105 dB peak
Power options	100V: 30W / 15W
Recommended amplifier power	60 W RMS
Transducers	
Ways	1
Driver	3" woofer
Nominal impedance	667Ω / 333Ω
Physical	
Connection type	Spring terminals
Power type selector	Changing the position of the terminals
Installation options	Wall or false ceiling
Enclosure material	ABS
Grille material	Aluminium, paintable
Finished color	White (RAL 9003)
Recommended cut out diameter	147 x 95 mm / 5.79"x3.74"
Required depth	80 mm / 3,14"
Ceiling thickness	2mm / 0.078" min 40mm / 1.57" max
Dimensions (WxHxD)	110 x 165 x 80 mm / 4.33 x 6.5 x 3.15 in.
Weight	0.9 kg / 1.98 lb

¹10dB below the sound pressure level at specified sensitivity

²6dB below the sound pressure level than that at the direction of maximum level, Average from 1 kHz to 4 kHz.

³Measured on-axis, far field and referenced to 1 meter by inverse square law. Average from 100 Hz to 10 kHz.

⁴Calculated from sensitivity and power handling specifications, exclusive of power compression

Mechanical diagrams

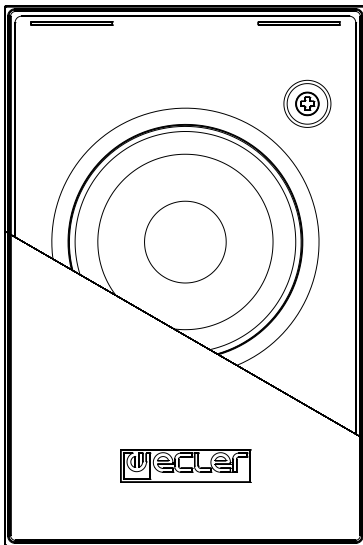

FRONT

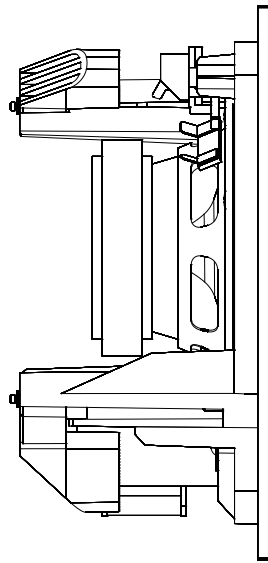

SIDE

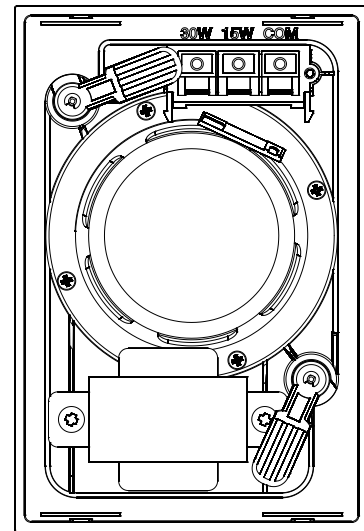

REAR

All product characteristics are subject to variation due to production tolerances. **NEEC AUDIO BARCELONA S.L.** reserves the right to make changes or improvements in the design or manufacturing that may affect these product specifications.

For technical queries contact your supplier, distributor or complete the contact form on our website, in [Support / Technical requests](#).

Motors, 166-168 08038 Barcelona - Spain - (+34) 932238403 | information@ecler.com | www.ecler.com